

mitsubishi

三菱工業用ミシン部品カタログ

Industrial Sewing Machine Parts Catalog

Model PLK-G2010R

	目次	CONTENTS	Page
A	本体構成	Construction	1
B	本体関係(1)	Arm bed & it's accessories (1)	2
C	本体関係(2)	Arm bed & it's accessories (2)	4
D	本体関係(3)	Arm bed & it's accessories (3)	6
E	縫い機構(1)	Sewing mechanism (1)	8
F	縫い機構(2)	Sewing mechanism (2)	10
G	中押え機構(1)	Presser bar lifting mechanism (1)	12
H	中押え機構(2)	Presser bar lifting mechanism (2)	14
J	糸切り機構	Thread trimming mechanism	16
K	X-Yテーブル機構	X-Y table mechanism	18
L	外押え機構(1)	Work holder mechanism (1)	20
M	外押え機構(2)	Work holder mechanism (2)	22
N	ワイパー機構	Wiper mechanism	24
P	給油機構	Oil lubrication mechanism	26
Q	配線・配管関係	Cable component & Pneumatic control unit	28
R	テーブル関係	Table & Stand	30
S	付属品(1)	Accessories (1)	32
T	付属品(2)	Accessories (2)	34
U	オプションパーツ	Option parts	36
	索引	Index	38

部品コードの採番形式

MITSUBISHI SPARE PARTS No. Designation system

1. 部品コードについて CONCERNING PARTS CODE.

部品をご注文される場合は、部品コードをお知らせください。

Please inform the part number, when these parts are ordered.

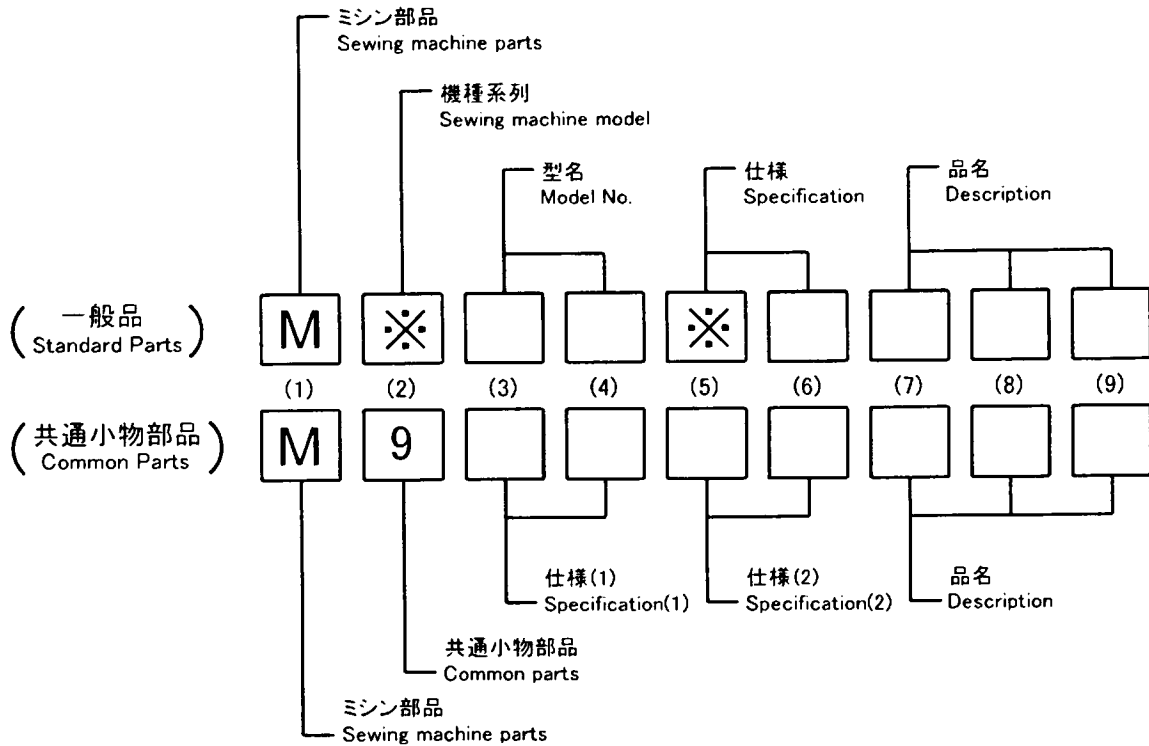

【 例 Example 】

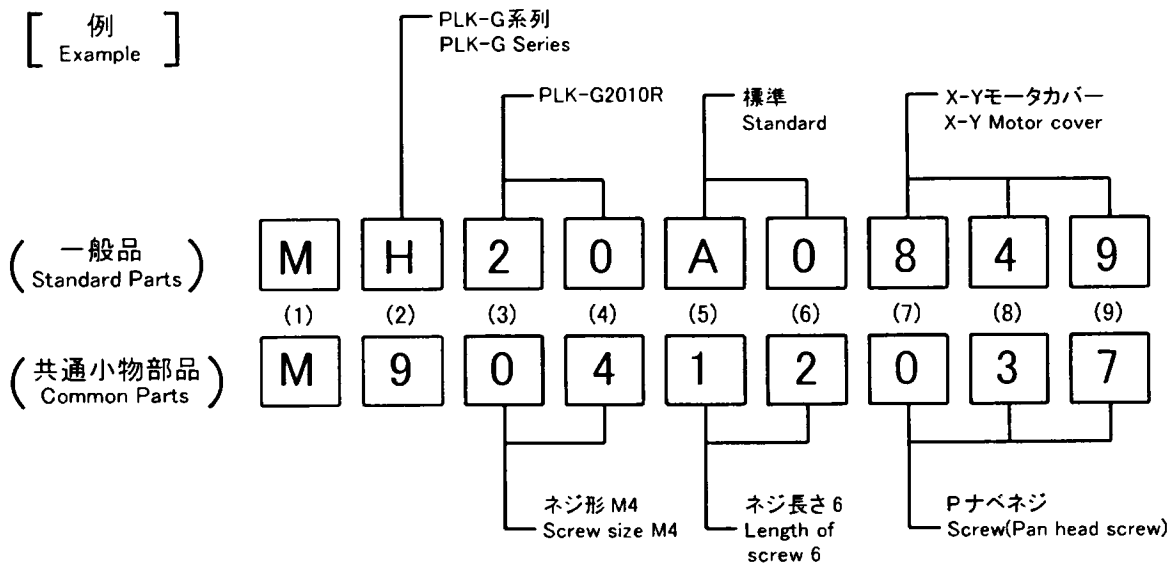

2. 変更マークについて CONCERNING MODIFICATION MARK.

変更マーク欄に*記号のある部品は、形状、寸法などの変更履歴がありますので、ご注文の際にはご使用の製品の製造番号と合わせてご覧ください。

The parts marked with * in the modification column has been changed the shape or size etc. So when these modified parts are ordered please inform the serial number of the sewing machine.

注：一般品についての機種型名は、その部品が最初に使用された機種型名を示します。従って長期にわたる場合は、機種の改廃が行われるため、当初の機種以外の機種で使用されている場合があります。

Sewing machine Models, of Standard Parts are Indicated model of these parts are registered firstly. Parts are used for not only the indicated model, but also another models, in reason of New development, improvement after.

A 全体構成
CONSTRUCTION

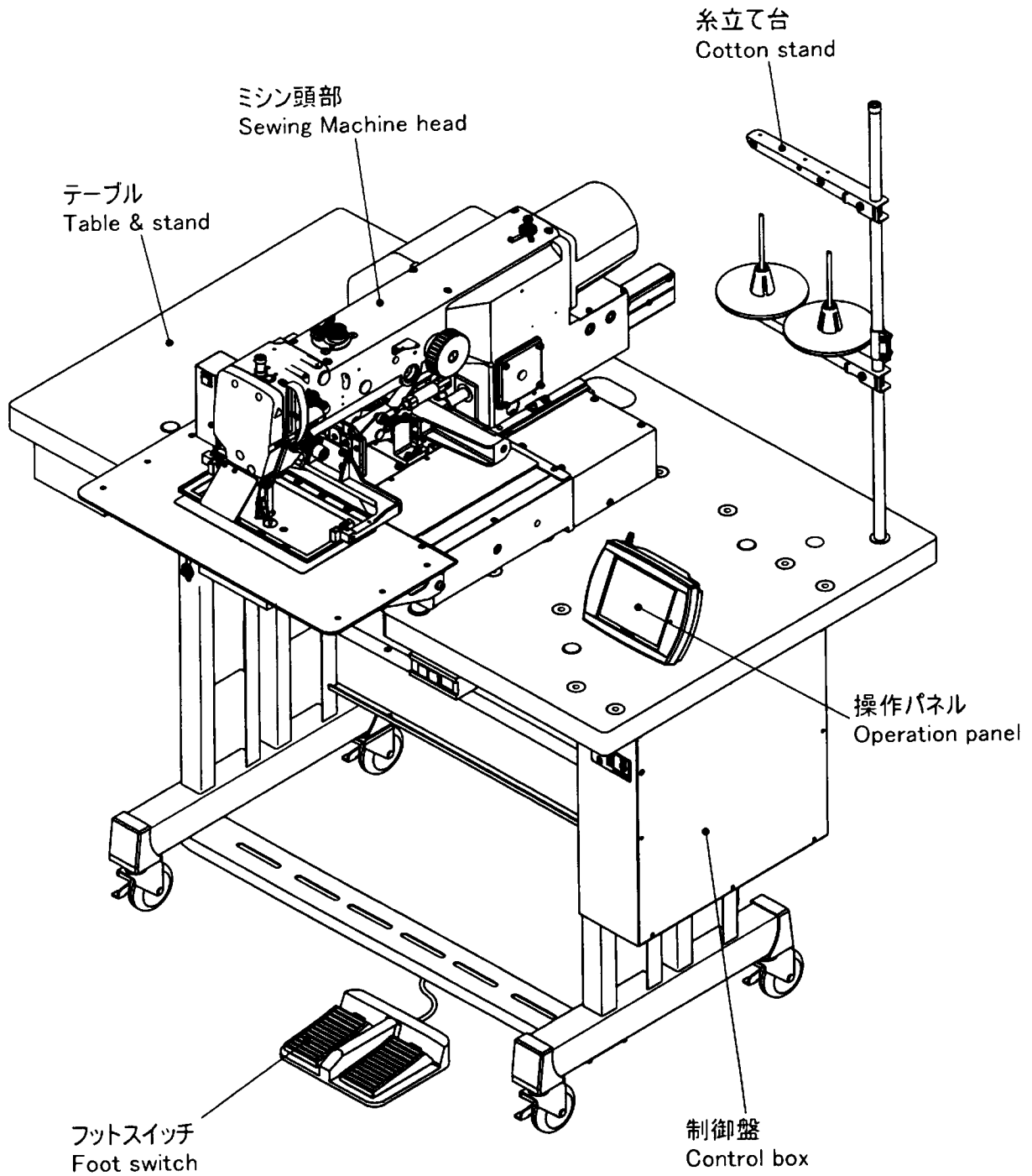

注1 : Fig.No.の採番していない部品は単体で支給することはできません。セットにて支給いたします。

Remarks 1) The parts which Fig.No. are not marked are not available individually.
It can be supplied with the whole component.

㊦ 本体関係(1)
ARM BED & IT'S ACCESSORIES

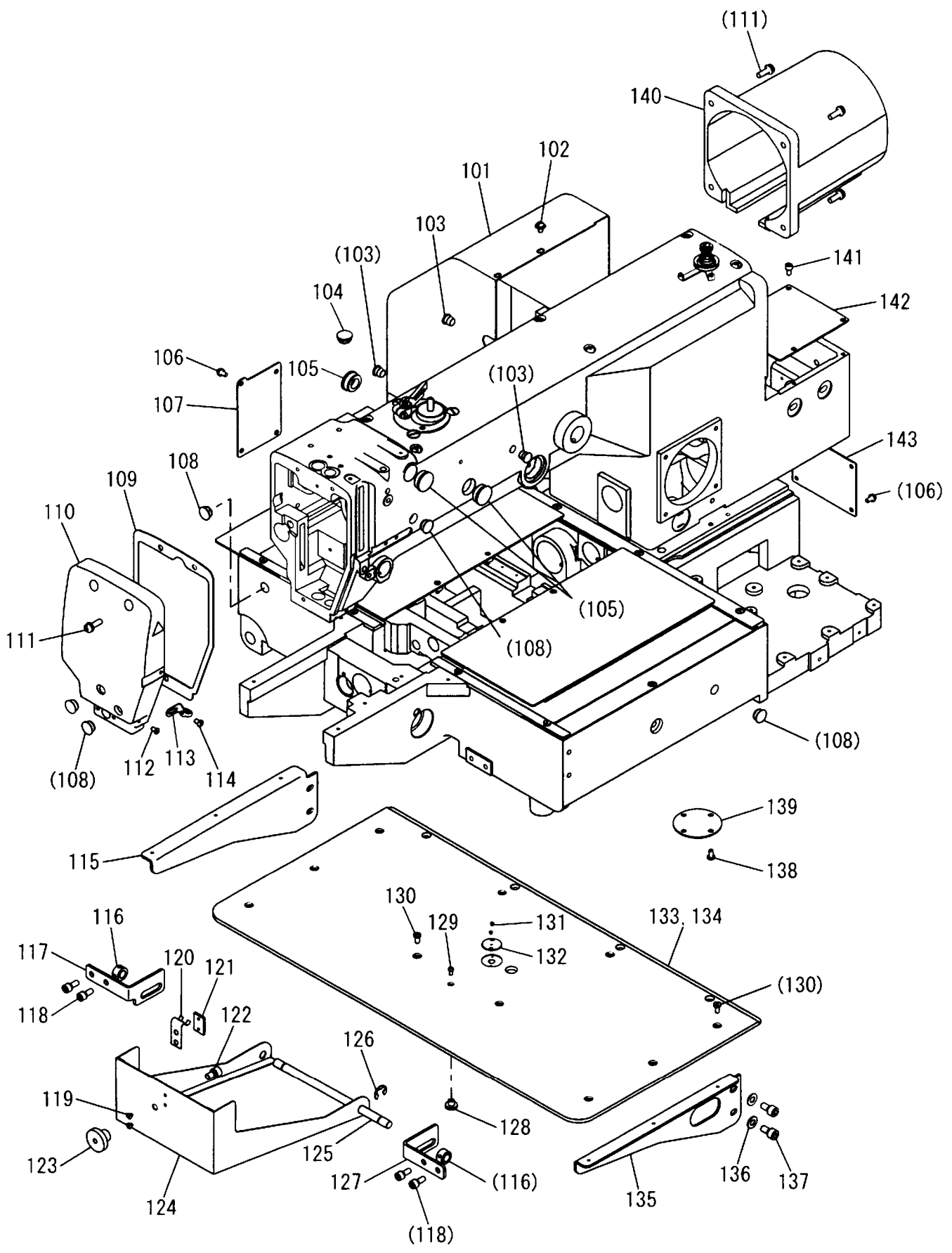

[B] 本体関係(1)

ARM BED & IT'S ACCESSORIES(1)

Fig no.	変更 Mod.	部品コード Parts no.	品名	Description	数量 Amt. Req.
B 101		MH20A0849	X-Yモータカバー	X-Y Motor cover	1
B 102		M91071004	SW-MWブラマイナネジ M4X8	Screw M4X8	5
B 103		M90883080	ゴムセン φ8.8	Rubber plug φ8.8	3
B 104		M91304080	ゴムセン φ13	Rubber plug φ13	1
B 105		M91910080	ゴムセン φ19	Rubber plug φ19	3
B 106		M91054004	SW-PWブラマイナネジ M4X8	Screw M4X8	8
B 107		MH10A0742	フタ	Cover	1
B 108		M91182080	ゴムセン φ11.8	Rubber plug φ11.8	5
B 109		MH10A0691	ガスケット	Gasket	1
B 110		MH10A0830	メンタ	Face cover	1
B 111		M91333004	SW-PWブラマイナネジ M5X16	Screw M5X16	7
B 112		M90908003	マルヒラネジ 9/64(40)X6	Screw 9/64(40)X6	1
☆ B 113		MG43A1181	イトアンナイ	Thread guide	1
B 114		M91011004	ブラマイナネジ M4X6	Screw M4X6	1
B 115		MH20A0429	ササエカナグ (ヒタリ)	Bracket (left)	1
B 116		ME20A0352	セットカラー	Set collar	2
B 117		MH20A7339	カバーガイド (ヒタリ)	Cover guide (left)	1
B 118		M95002017	セフティソケット M5X12	Safety socket bolt M5X12	4
B 119		M90906003	マルヒラネジ 9/64(40)X3.2	Screw 9/64(40)X3.2	2
B 120		MH27A0361	カケガネ	Latch	1
B 121		MH27A0420	コテイタ	Plate	1
B 122		M96008017	セフティソケット M6X10	Safety socket bolt M6X10	1
B 123		MH27A0650	ローレットノブ	Knurled knobs	1
B 124		MH20A0339	カマカバー	Hook cover	1
B 125		MH27A0454	シク	Shaft	1
B 126		M90511065	Eガトメワ 6	E-type retaining ring 6	2
B 127		MH20A8339	カバーガイド (ミキ)	Cover guide (right)	1
B 128		MH27A1650	ローレットノブ	Knurled knobs	1
B 129		M90856004	ブラマイナネジ M3X6	Screw M3X6	1
☆ B 130		M90990002	ヒラネジ M4X8	Screw M4X8	10
☆ B 131		M90605010	サラネジ 3/32(56)X2.8	Screw 3/32(56)X2.8	2
☆ B 132		MS02A1101	ハリアナイタ	Needle plate	1
B 133		MH20A0470	スベリイタ	Slide plate	1
☆ B 134		MB61A0470	ホコフィルム	Film sheet	1
B 135		MH20A1429	ササエカナグ (ミキ)	Bracket (right)	1
B 136		M90631050	ミガキサガネ 6	Washer 6	4
B 137		M96002017	セフティソケット M6X12	Safety socket bolt M6X12	4
B 138		M94005022	ロックアナツキホルタンホルト M4X8	Bolt M4X8	4
B 139		MH27A0742	フタ	Cover	1
B 140		MH27A1849	シュシクモータカバー	Main shaft motor cover	1
B 141		M94002017	セフティソケット M4X8	Safety socket bolt M4X8	4
B 142		MH20A0776	Yシクベルトカバー	Cover	1
B 143		MH27A1339	カバー	Cover	1

C 本体関係(2)
 ARM BED & IT'S ACCESSORIES(2)

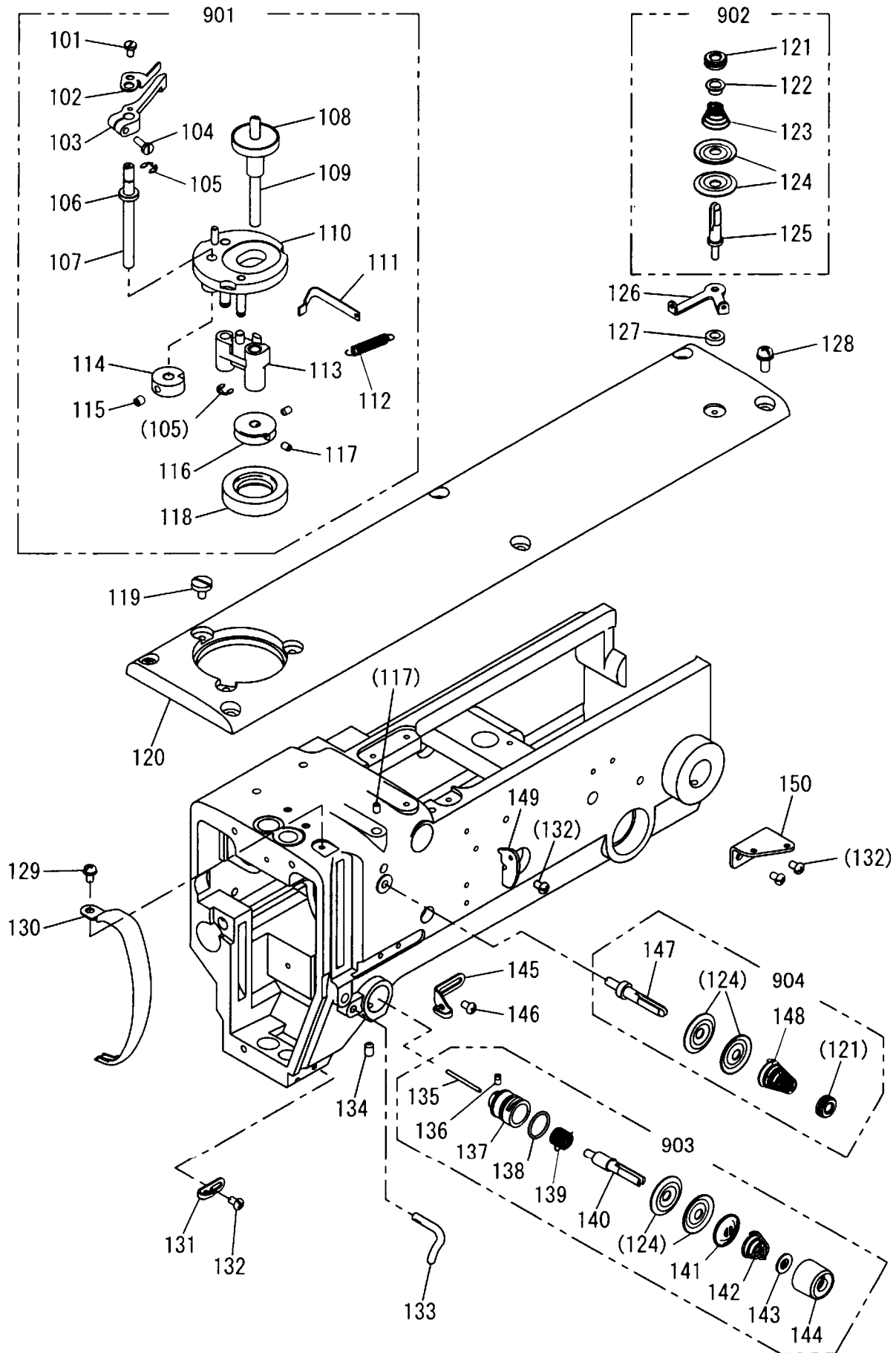

[C] 本体関係(2)

ARM BED & IT'S ACCESSORIES(2)

Fig no.	変更 Mod.	部品コード Parts no.	部品名	Description	数量 Amt. Req.
C 101		M90920002	ヒラネジ 9/64(40)X6.5	Screw 9/64(40)X6.5	1
C 102		MF13A0551	チョウセツイタ	Adjustment plate	1
C 103		MF13A0950	レバー	Lever	1
C 104		M90939002	ヒラネジ 9/64(40)X11	Screw 9/64(40)X11	1
C 105		M70535065	Eが外メウ 5	E-type stop ring 5	2
C 106		MF13A0750	ブッシュ	Spacer	1
C 107		MH10A0348	カムジク	Cam shaft	1
C 108		MF13A0793	ホビンサ	Bobbin cushion	1
C 109		MH27A0191	イトマキジク	Bobbin winder shaft	1
C 110		MF13A2191	イトマキダイクミタテ	Bobbin winder base assy	1
C 111		MF13A0192	イタバネ	Leaf spring	1
C 112		MF13A0572	ツルマキバネ	Spring	1
C 113		MF13A0191	イトマキウテクミタテ	Bobbin winder shaft holder assy	1
C 114		MF13A0350	イトマキカム	Bobbin winder cam	1
C 115		M95002020	ロッククアナツキメネジ M5X6	Screw M5X6	1
C 116		MH10A0194	イトマキグルマ	Bobbin winder wheel	1
C 117		M91053020	ロッククアナツキメネジ M4X6	Screw M4X6	3
C 118		MH10A0417	ゴムワ	Rubber ring	1
C 119		M91150003	マルヒラネジ 11/64(40)X8	Screw 11/64(40)X8	3
C 120		MH27A0600	トップカバー	Top cover	1
☆ C 121		M91602046	ツマミナット	Thumb nut	2
☆ C 122		MM11A0702	バネアンナイ	Spring guide	1
☆ C 123		MM11A0245	エンスイバネ	Thread tension spring	1
☆ C 124		MF10A0555	チョウシガラ	Thread tension discs	6
☆ C 125		MS14A0553	チョウシボウ	Thread tension stud	1
☆ C 126		MS14A1180	イトアンナイ	Thread guide	1
☆ C 127		MG75A1476	スパーサ	Spacer	1
C 128		M91331004	SW-PWブライナネジ M5X12	Screw M5X12	6
C 129		M91054004	SW-PWブライナネジ M4X8	Screw M4X8	1
C 130		MH10A0584	テンピンカバー	Thread take-up lever guard	1
☆ C 131		MF10A0181	イトアンナイ	Thread guide	1
C 132		M91011004	ブライナネジ M4X6	Screw M4X6	4
☆ C 133		MF70A1180	イトアンナイ	Thread guide	1
C 134		M95004020	ロッククアナツキメネジ M5X8	Screw M5X8	1
☆ C 135		M90204060	ピン	Pin	1
C 136		M90901002	ヒラネジ 9/64(40)X4	Screw 9/64(40)X4	1
☆ C 137		MF10A0709	ブッシュ	Regulator casing	1
C 138		M91501085	オリング	O-ring	1
☆ C 139		MF10A0187	イトリバネ	Thread take-up spring	1
☆ C 140		MF10A0553	チョウシボウ	Thread tension stud	1
☆ C 141		MM11A0556	チョウシガラオサエ	Disc retaining plate	1
☆ C 142		MN52A1245	エンスイバネ	Thread tension spring	1
☆ C 143		MT60A0802	マワリドメ	Thumb nut revolution stopper	1
☆ C 144		M91610046	ツマミナット	Thumb nut	1
☆ C 145		MG43A0181	イトアンナイ	Thread guide	1
C 146		M91084004	ブライナネジ M4X6	Screw M4X6	1
C 147		MH10A0553	チョウシボウ	Thread tension stud	1
C 148		MH10A0245	エンスイバネ	Thread tension spring	1
C 149		MH10A2181	イトアンナイ	Thread guide	1
C 150		MH10A3181	イトアンナイ	Thread guide	1
C 901		MH27E0190	イトマキウチクミタテ	Bobbin winder complete	1
☆ C 902		MS14E0180	チョウセツクミタテ	Thread tension Regulator assy	1
C 903		MH10E0210	チョウセツクミタテ	Thread tension Regulator assy	1
C 904		MH27E0550	イトチョウセツクミタテ	Thread tension Regulator assy	1

☆印はPLK-E2010R共通部品を示します。
☆ indicates PLK-E2010R common parts.

□ 本体関係(3)
ARM BED & IT'S ACCESSORIES(3)

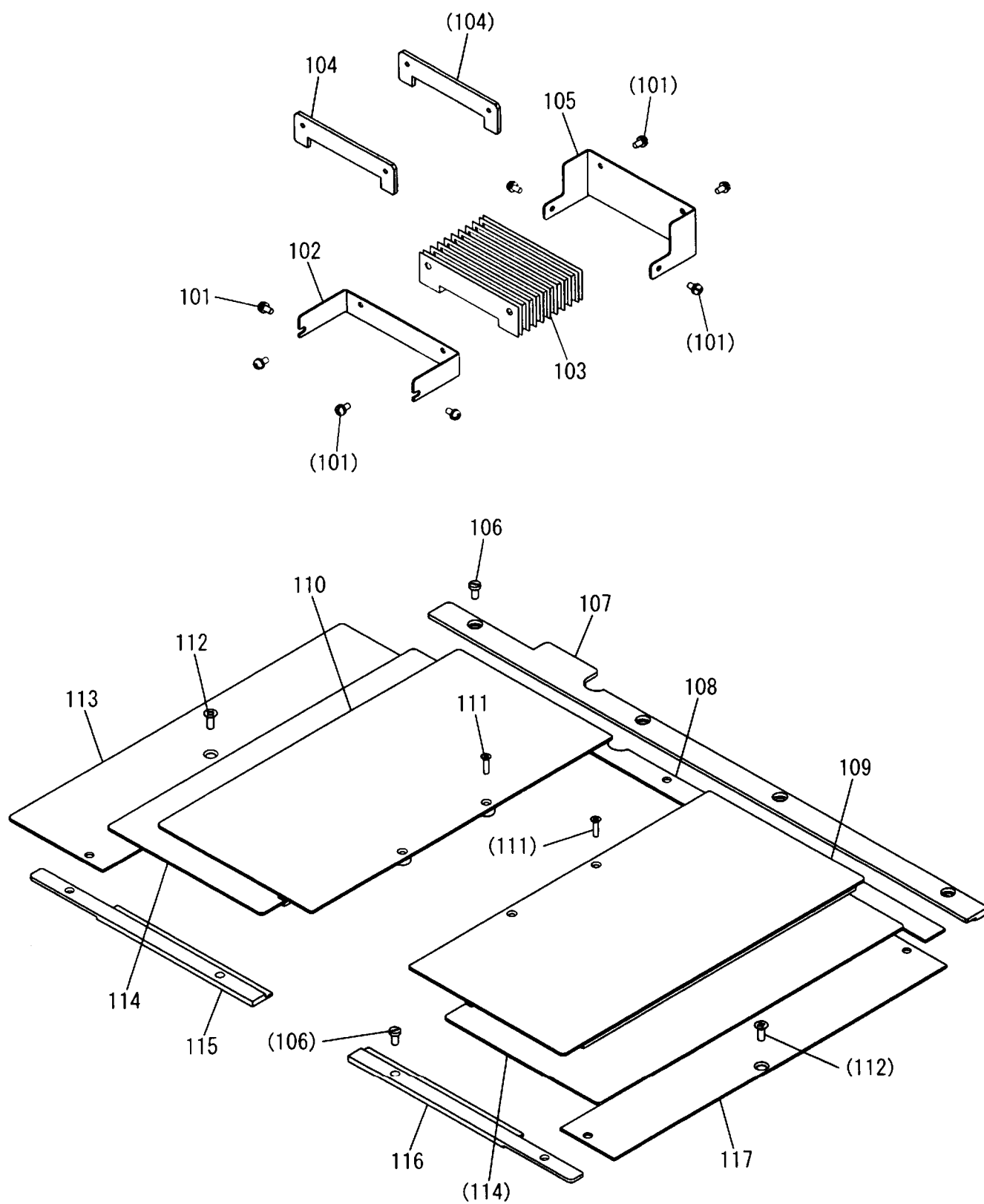

[D] 本体関係(3)

ARM BED & IT'S ACCESSORIES(3)

Fig no.	変更 Mod.	部品コード Parts no.	品名	Description	数量 Amt. Req.
D 101		M90859004	SW-PWブラマイナネジ M3X6	Screw M3X6	8
D 102		MH20A0601	ジャバラトリツケイタ (マI)	Shutter adapter (front)	1
☆ D 103		MB61A0458	ジャバラ	Shutter	1
D 104		MH20A0257	オサエイタ	Plate	2
D 105		MH20A1601	ジャバラトリツケイタ (ウシロ)	Shutter adapter (rear)	1
☆ D 106		M90990002	ヒラネジ M4X8	Screw M4X8	8
D 107		MH20A2359	カバーガイドクミタテ (ウシロ)	Cover guide assy (rear)	1
D 108		MH20A0476	スペーサ (ウシロ)	Spacer (rear)	1
D 109		MH20A1339	Xカバーイタクミタテ (ミキ)	X-cover plate assy (right)	1
D 110		MH20A2339	Xカバーイタクミタテ (ヒタリ)	X-cover plate assy (left)	1
D 111		M90862004	Pサラネジ M3X12	Screw M3X12	4
D 112		M91400010	Pサラネジ M4X8	Screw M4X8	2
D 113		MH20A3339	X-Yカバー	X-Y cover	1
D 114		MH20A4339	Xイトウカバークミタテ	X-movable plate assy	2
D 115		MH20A1476	スペーサクミタテ (ヒタリ)	Spacer assy (left)	1
D 116		MH20A2476	スペーサクミタテ (ミキ)	Spacer assy (right)	1
D 117		MH20A5339	X-Yカバー	X-Y cover	1

E 縫い機構(1)
 SEWING MECHANISM

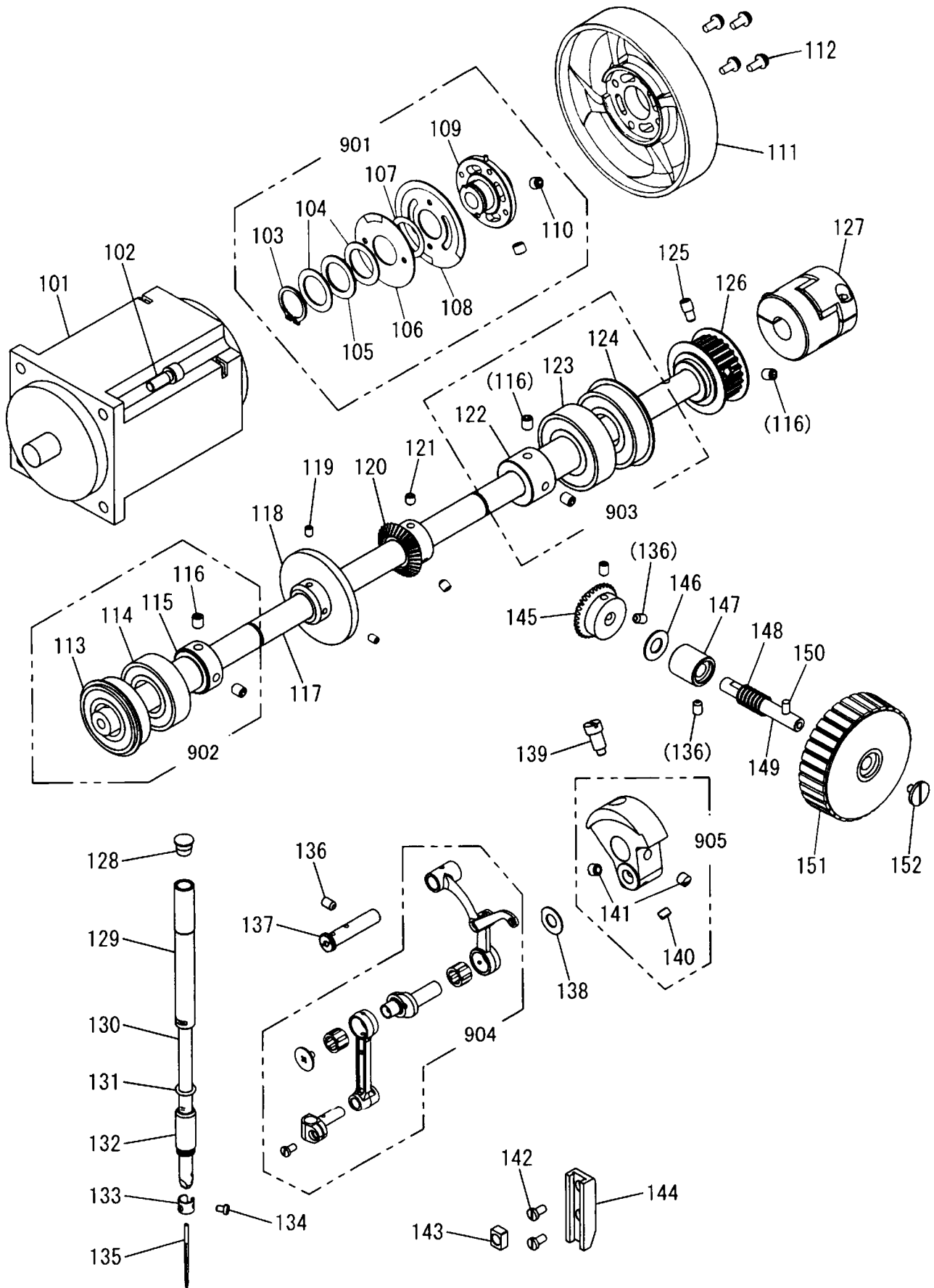

[E]縫い機構(1)
SEWING MECHANISM(1)

Fig no.	変更 Mod.	部品コード Parts no.	品名	Description	数量 Amt. Req.
E 101		MH10E2848	シュンクモータ	Main shaft motor	1
E 102		M96001017	セフティソケット M6X16	Safety socket bolt M6X16	4
E 103		M90337065	Cタイプメウ 18	C-type retaining ring 18	1
E 104		MF17A1476	スペーサ B	Spacer B	2
E 105		M93016050	ナミワッシャ	Wave washer	1
E 106		MH10A1694	ハンシャパン (ウエ)	Command disk (up)	1
E 107		MF17A2476	スペーサ A	Spacer A	1
E 108		MH10A0694	ハンシャパン (シタ)	Command disk (down)	1
E 109		MH10A0750	ブッシュクミ	Bushing assy	1
E 110		M91609020	ロックアナツキトメネジ 1/4(40)X5.5	Screw 1/4(40)X5.5	2
E 111		MH10A0682	プーリー	Pulley	1
E 112		M90409037	SW-PW Pナベネジ M4X10	Screw M4X10	4
E 113		MH10A1456	ジクウケ	Ball bearing	1
E 114		MH10A0456	ジクウケ	Ball bearing	1
E 115		MH10A1750	ブッシュ	Bushing	1
E 116		M91650020	ロックアナツキトメネジ M6X8	Screw M6X8	5
E 117		MH20A0230	ウワジク	Upper shaft	1
☆ E 118		MS14A0682	プーリー	Pulley	1
E 119		M91053020	ロックアナツキトメネジ M4X6	Screw M4X6	2
E 120		MH10A1722	ウワジクマイタキヤ	Gear	1
E 121		M95002020	ロックアナツキトメネジ M5X6	Screw M5X6	2
E 122		MH27A2750	ブッシュ	Bushing	1
E 123		MH27A0456	ジクウケ	Ball bearing	1
E 124		MN10A1456	ジクウケ	Ball bearing	1
E 125		M96001005	ロックアナツキトメネジホウサキ M6X6	Screw M6X6	1
E 126		MF13A0767	タイミングベルトグルマウエ	Belt pulley (upper)	1
E 127		MH10A0364	カップリング	Coupling	1
E 128		M90883080	ゴムセン φ8.8	Rubber plug φ8.8	1
E 129		MH10A0663	ハリホウメタル (ウエ)	Needle bar bushing (upper)	1
E 130		MH27A0660	ハリホウ	Needle bar	1
E 131		M90500085	Oリング	O-ring	1
E 132		MH27A0664	ハリホウメタル (シタ)	Needle bar bushing (lower)	1
☆ E 133		MG42A0181	イトアンナイ	Thread guide	1
☆ E 134		M90815002	ヒラネジ 1/8(44)X4.5	Screw 1/8(44)X4.5	1
☆ E 135		MS02A0128	ミシンハリ DPX17#18	Needle DPX17#18	1
E 136		M95004020	ロックアナツキトメネジ M5X8	Screw M5X8	4
E 137		MH10A0530	ダンツクジクミタテ	Stepped shaft assy	1
E 138		M90836050	ワッシャ	Washer	1
E 139		M91802006	ヒラネジホウサキ 9/32(28)	Set screw 9/32(28)	1
E 140		M91602001	トメネジ 1/4(40)X4	Screw 1/4(40)X4	1
E 141		M91606001	トメネジ 1/4(40)X6	Screw 1/4(40)X6	2
☆ E 142		M90990002	ヒラネジ M4X8	Screw M4X8	2
E 143		MF10A0325	カクコマ	Square block	1
E 144		MS01A0155	アンナイダイ	Guide bracket	1
E 145		MH10A0722	マイタキヤ	Gear	1
E 146		MH10A0416	カンショウゴム	Rubber cushion	1
E 147		MH27A0833	メタル	Bushing	1
E 148		MH10A0572	ツルマキパネ	Spring	1
E 149		MH27A1454	ジク	Shaft	1
☆ E 150		M90406064	スプリングピン φ4X14	Spring pin φ4X14	1
☆ E 151		ME25A0682	プーリー	Pulley	1
☆ E 152		M91119002	ヒラネジ 11/64(40)X6.8	Screw 11/64(40)X6.8	1
E 901		MH10A4750	ブッシュクミタテ	Bushing assy	1
E 902		MH10E0456	ジクウケクミタテ (マエ)	Ball bearing assy (front)	1
E 903		MH27A2456	ジクウケクミタテ (ウシロ)	Ball bearing assy (rear)	1
E 904		MH27E0580	テンピンハリクミタテ	Thread take-up lever assy	1
E 905		MH27E0383	クランククミタテ	Crank assy	1

☆印はPLK-E2010R共通部品を示します。
☆ indicates PLK-E2010R common parts.

F 縫い機構(2)
SEWING MECHANISM(2)

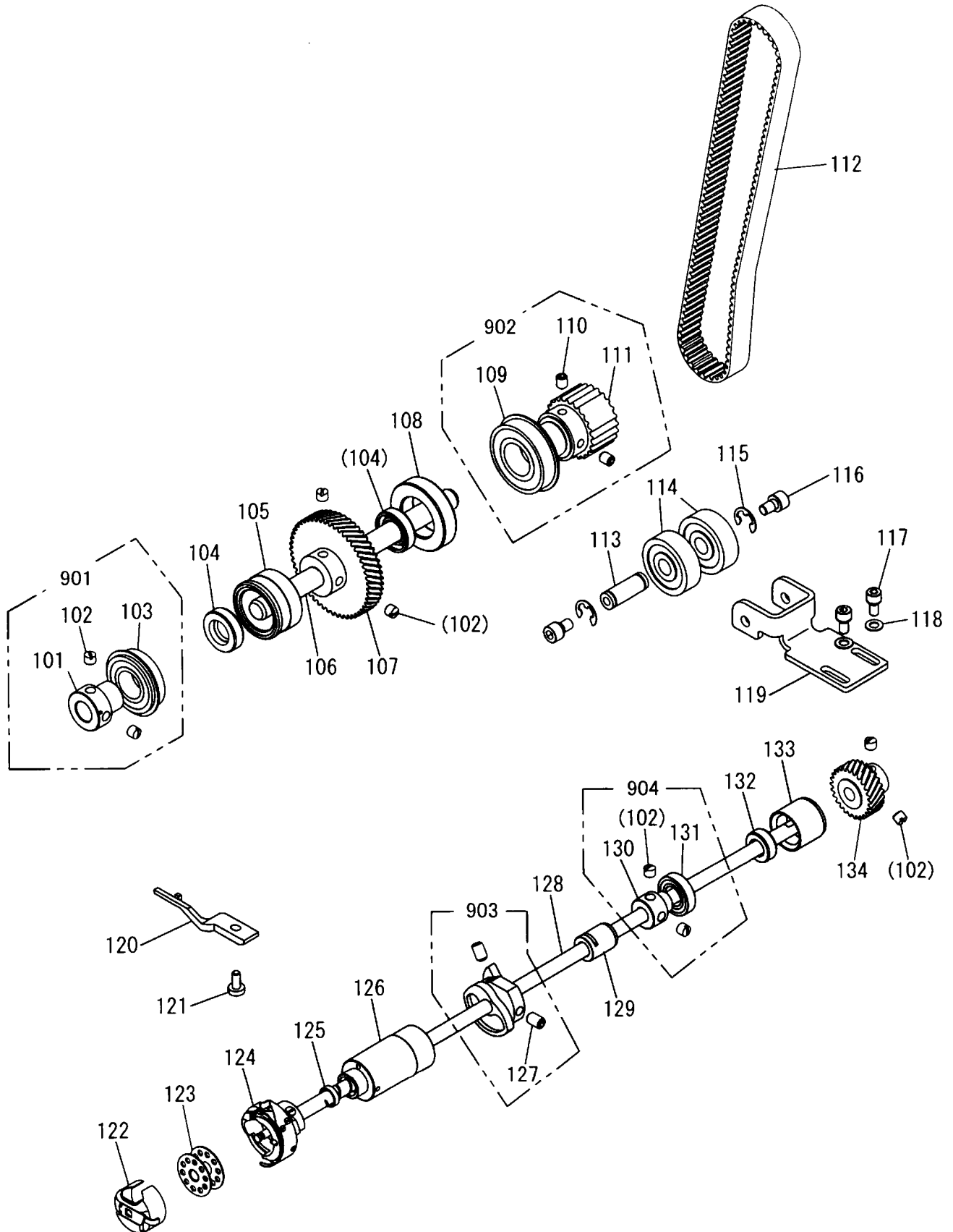

[F] 縫い機構(2)
SEWING MECHANISM(2)

Fig no.	変更 Mod.	部品コード Parts no.	品名	Description	数量 Amt. Req.
F 101		MF13A9750	ブッシュ	Bushing	1
F 102		M91606001	トメネジ 1/4(40)X5	Screw 1/4(40)X5	8
F 103		MF13A0456	ジクウケ	Ball bearing	1
F 104		M91200086	オイルシール	Oil seal	2
F 105		MH27A4750	ブッシュ	Bushing	1
F 106		MH27A1450	シタジク (ヒタリ)	Lower shaft (L)	1
F 107		MF13A1683	ハスバハグルマダイ	Gear (large)	1
F 108		MF13A4750	ブッシュ	Bushing	1
F 109		MN70A2456	ジクウケ	Ball bearing	1
F 110		M91650020	ロックワナツキトメネジ M6X8	Screw M6X8	2
F 111		MF13A2767	タイミングベルトグルマシタ	Belt pulley (lower)	1
F 112		MH27A0523	タイミングベルト	Timing belt	1
F 113		MH27A2454	テンションシャフト	Shaft	1
F 114		MH27A3456	ジクウケ	Ball bearing	2
F 115		M90604065	Eガタメワ 8	E-type retaining ring 8	2
F 116		M96008017	セフティソケット M6X10	Safety socket bolt M6X10	2
F 117		M95002017	セフティソケット M5X12	Safety socket bolt M5X12	2
F 118		M90512050	コサガネ 5	Washer 5	2
F 119		MH27A0770	テンションベース	Base	1
☆ F 120		MF20A0229	ウチガマトメ	Hook positioner	1
☆ F 121		M91118002	ヒラネジ 11/64(40)X10	Screw 11/64(40)X10	1
☆ F 122		MG44E0125	ホビンケース	Bobbin case	1
☆ F 123		MF25B0123	ホビン	Bobbin	1
☆ F 124		ME20A0120	カマクミタテ	Hook complete	1
☆ F 125		M90800086	オイルシール	Oil seal	1
☆ F 126		MS10A0451	シタジクメタル (ヒタリ)	Hook shaft bushing (L)	1
☆ F 127		M91602020	ロックワナツキトメネジ 1/4(40)X10	Screw 1/4(40)X10	2
F 128		MH20A0450	シタジク	Lower shaft	1
F 129		MH20A0453	シタジクメタル (ナカ)	Hook shaft bushing (M)	1
F 130		MH27A5750	ブッシュ	Bushing	1
F 131		MF13A1456	ジクウケ	Ball bearing	1
F 132		M90804086	オイルシール	Oil seal	1
F 133		MF13A0452	シタジクメタル (ミキ)	Hook shaft bushing (R)	1
F 134		MF13A0683	ハスバハグルマショウ	Gear (small)	1
F 901		MF13E6456	ジクウケクミタテ	Ball bearing assy	1
F 902		MF13E1767	タイミングベルトグルマシタクミタテ	Belt pulley (lower) assy	1
☆ F 903		MF01E0350	イトキリカム	Thread trimmer cam	1
F 904		MH27A4456	ジクウケクミタテ	Hook shaft bushing assy	1

㊄ 中押え機構(1)
PRESSER BAR LIFTING MECHANISM(1)

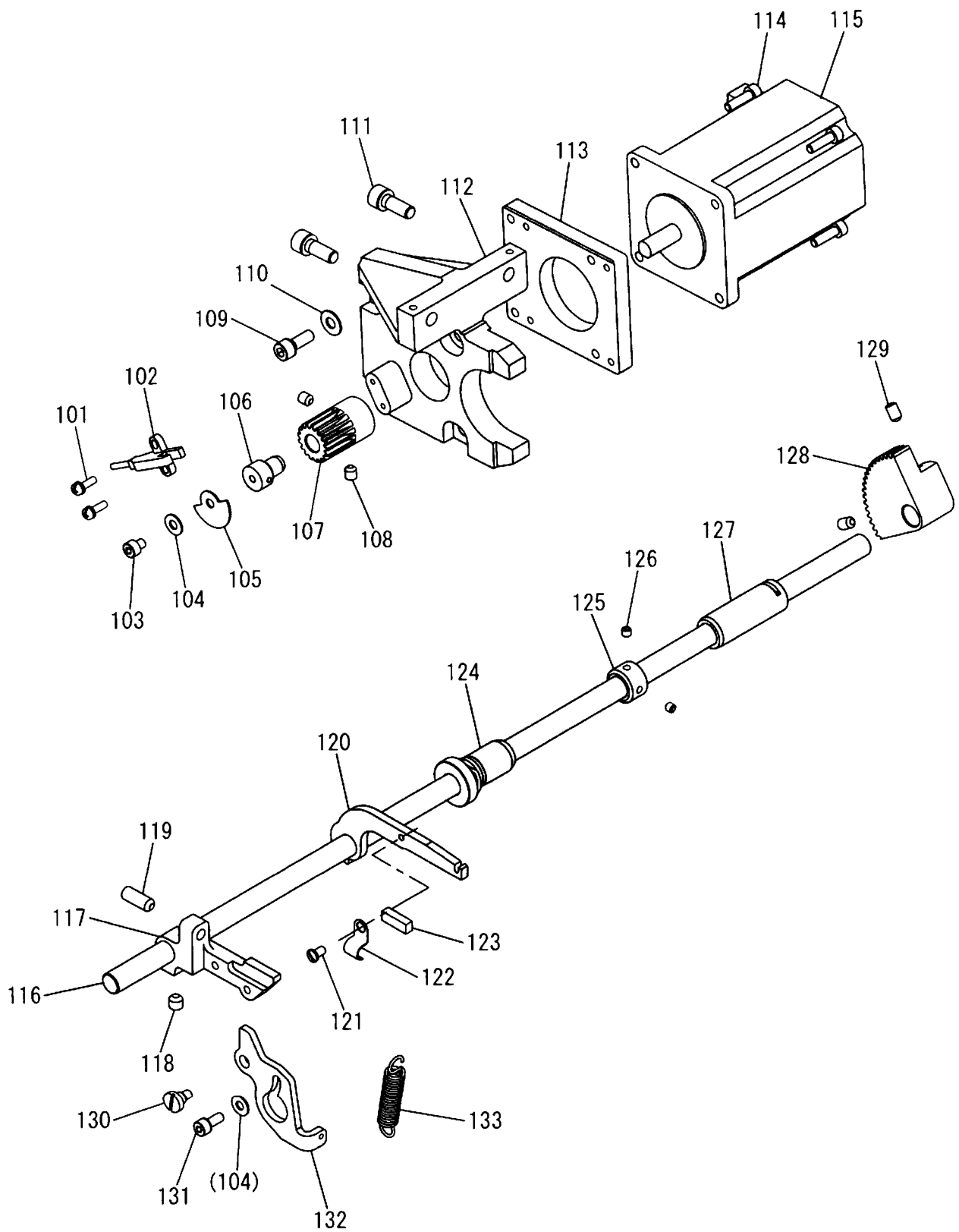

[G] 中押え機構(1)

PRESSER BAR LIFTING MECHANISM

Fig no.	変更 Mod.	部品コード Parts no.	品名	Description	数量 Amt. Req.
G 101		M90971004	SW-PWブラマイナネジ M3X10	Screw M3X10	2
G 102		MH20A0501	フォトセンサ	Photo micro sensor	1
G 103		M94009021	ロックアナツキホルト M4X5	Socket bolt M4X5	1
G 104		M90421050	ミカキサガネ 4	Washer 4	2
G 105		MH10A1407	ケンシュツパン	Detector plate	1
G 106		MH10A2476	ケンシュツパンスペーサ	Detector plate spacer	1
G 107		MH10A2722	ヒラハグルマ	Gear	1
G 108		M94001001	ナイロックメネジ M5X6	Screw M5X6	2
G 109		M95014017	セフティソケット M5X14	Safety socket bolt M5X14	4
G 110		M90511050	ミカキサガネ 5	Washer 5	4
G 111		M96001017	セフティソケット M6X16	Safety socket bolt M6X16	2
G 112		MH10A1850	ナカオサエモータダイ	Presser foot motor bracket	1
G 113		MH10A3476	モータスペーサ	Motor spacer	1
G 114		M94040021	ロックアナツキホルト M4X14	Socket bolt M4X14	4
G 115		MH10A1848	ステッピングモータ	Stepping motor	1
G 116		MH10A3390	ナカオサエクトウシク	Presser foot driving shaft	1
G 117		MH10A0252	ナカオサエアケレバー A	Presser foot lifting lever A	1
G 118		M96001020	ロックアナツキメネジ M6X6	Screw M6X6	1
G 119		M91651020	ロックアナツキメネジ M6X16	Screw M6X16	1
G 120		MH10A1252	ナカオサエアケレバー B	Presser foot lifting lever B	1
☆ G 121		M90909003	マルヒラネジ 9/64(40)X6	Screw 9/64(40)X6	1
☆ G 122		MN70A1780	ホルダ	Holder	1
G 123		MH10A1740	フェルト	Felt	1
G 124		MH20A0833	ナカオサエメタル (マエ)	Presser foot bushing (front)	1
G 125		MH10A1352	セットカラー	Set collar	1
G 126		M91055020	ロックアナツキメネジ M4X4	Screw M4X4	2
G 127		MH10A2833	ナカオサエメタル (ウシロ)	Presser foot bushing (rear)	1
G 128		MH10A1683	オウキハグルマ	Gear	1
G 129		M95004020	ロックアナツキメネジ M5X8	Screw M5X8	2
G 130		M91127015	ヒラネジダンツキ 11/64(40)X5	Screw 11/64(40)X5	1
G 131		M94001017	セフティソケット M4X10	Safety socket bolt M4X10	1
G 132		MH10A2708	ハネカケ	Hook plate	1
G 133		MH10A4572	ツルマキバネ	Spring	1

H 中押え機構(2)
PRESSER BAR LIFTING MECHANISM(2)

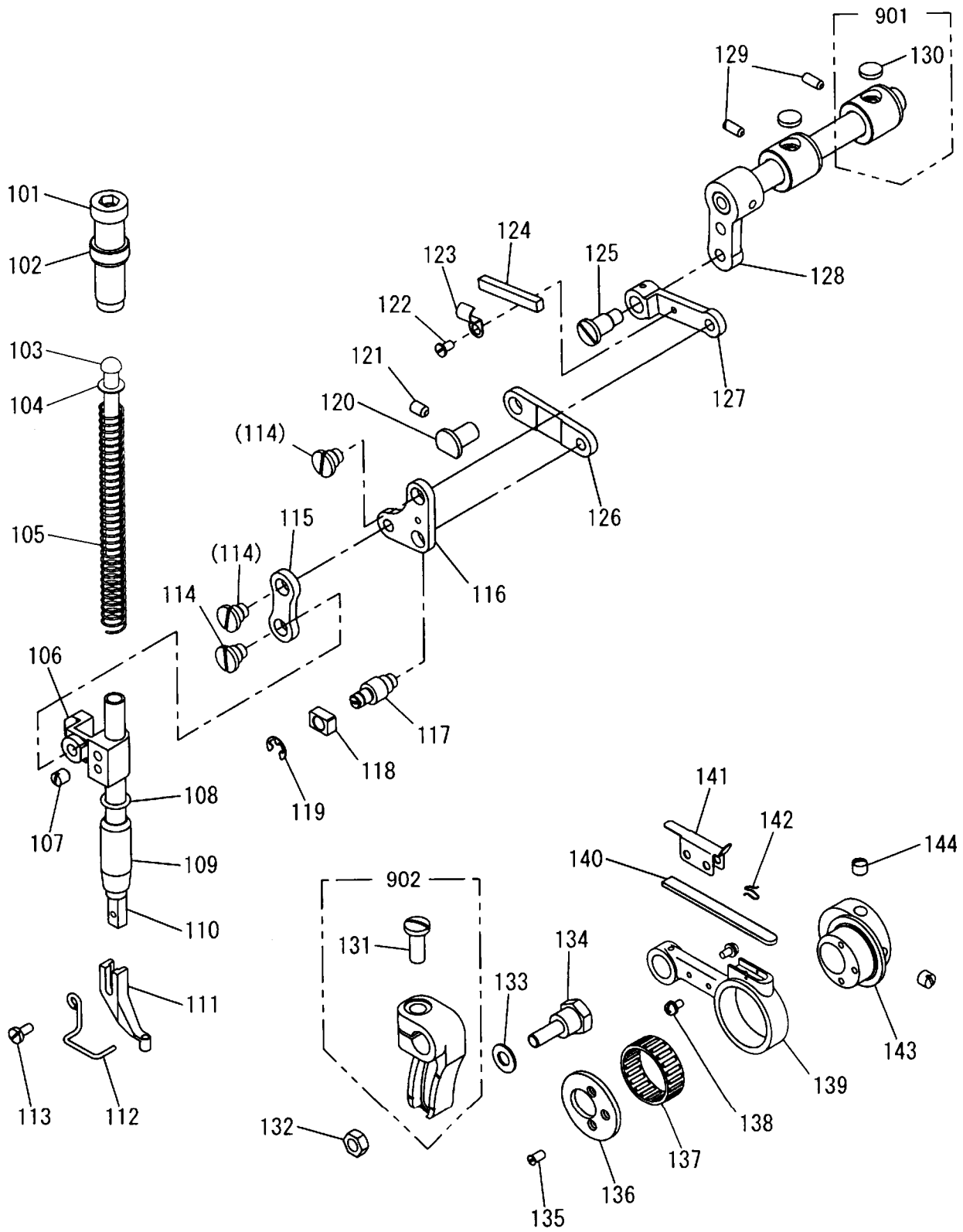

[H] 中押え機構(2)

PRESSER BAR LIFTING MECHANISM

Fig no.	変更 Mod.	部品コード Parts no.	品名	Description	数量 Amt. Req.
☆ H 101		M93220035	ツマミネジ 1/2(28)X43	Thumb screw 1/2(28)X43	1
☆ H 102		M93202047	ナット 1/2(28)	Nut 1/2(28)	1
H 103		MS03A0703	アンナイホウ	Presser bar guide	1
H 104		M90632050	コサガネ 6	Washer 6	1
☆ H 105		MS03A1572	ツルマキバネ	Spring	1
☆ H 106		MG75A0265	オサエホウダキ	Presser bar holder	1
☆ H 107		M91506001	トメネジ 15/64(28)X7	Screw 15/64(28)X7	1
H 108		M90600085	Oリング	O-ring	1
H 109		MH10A0267	オサエホウメタル	Presser bar bushing	1
☆ H 110		MS03A0262	オサエホウ	Presser bar	1
☆ H 111		MV30A0256	オサエ φ3	Presser foot φ3	1
H 112		MH10A0626	ニートルガード	Needle guard	1
☆ H 113		M90922002	ヒラネジ 9/64(40)X8	Screw 9/64(40)X8	1
H 114		M91690015	ヒラネジダンツキ 1/4(40)X4	Screw 1/4(40)X4	3
H 115		MH10A5910	リンク	Link	1
H 116		MH10A0763	ベルクランク	Bell crank	1
H 117		M91553015	ダンツキネジ 1/4(40)X4	Screw 1/4(40)X4	1
H 118		MF10A0325	カクコマ	Square block	1
H 119		M90505065	Eガトメワ 5	E-type retaining ring 5	1
H 120		MH10A0283	ツバツキジク	Stepped pin	1
H 121		M95004020	ロッカクアナツキトメネジ M5X8	Screw M5X8	1
☆ H 122		M90908003	マルヒラネジ 9/64(40)X6	Screw 9/64(40)X6	1
☆ H 123		MN70A1780	ホルダ	Holder	1
☆ H 124		MG30A0740	フェルト	Felt	1
H 125		M91691015	ヒラネジダンツキ 1/4(40)X7	Screw 1/4(40)X7	1
☆ H 126		ME10A7910	リンク	Link	1
H 127		MH10A1956	レンセツカン	Link	1
H 128		MH27A0228	ウテクミタテ	Arm shaft assy	1
H 129		M91058020	ロッカクアナツキトメネジ M4X10	Screw M4X10	2
H 130		MS10A1740	フェルト	Felt	2
☆ H 131		M91603003	マルヒラネジ 1/4(24)X16	Screw 1/4(24)X16	1
H 132		M91572045	Uナット M6X0.75	U-nut M6X0.75	1
H 133		M90631050	ミカキザガネ 6	Washer 6	1
H 134		M96011017	ダンツキホルト M6	Bolt M6	1
H 135		M90902011	マルヒラネジ 9/64(40)X7	Screw 9/64(40)X7	3
H 136		M98016050	ザガネ	Washer	1
H 137		MN35A0628	ニートルヘアリング	Needle bearing	1
H 138		M90859004	SW-PWブラマイナネジ M3X6	Screw M3X6	2
H 139		MH10A2956	レンセツカン	Link	1
H 140		MH10A2740	フェルト	Felt	1
H 141		MH10A1741	フェルトオサエ	Felt holder	1
☆ H 142		MF60A0700	センサイクバネ	Spring	1
H 143		MH10A0760	ヘンシンリン	Eccentric cam	1
☆ H 144		M91606001	トメネジ 1/4(40)X6	Screw 1/4(40)X6	2
H 901		MH10E0285	ジョウブジョウゲメタルクミタテ	Bushing assy	2
☆ H 902		MS02A0463	ウテ(ミキ)	Arm (right)	1

☆印はPLK-E2010R共通部品を示します。
 ☆ indicates PLK-E2010R common parts.

J 糸切り機構
 THREAD TRIMMING MECHANISM

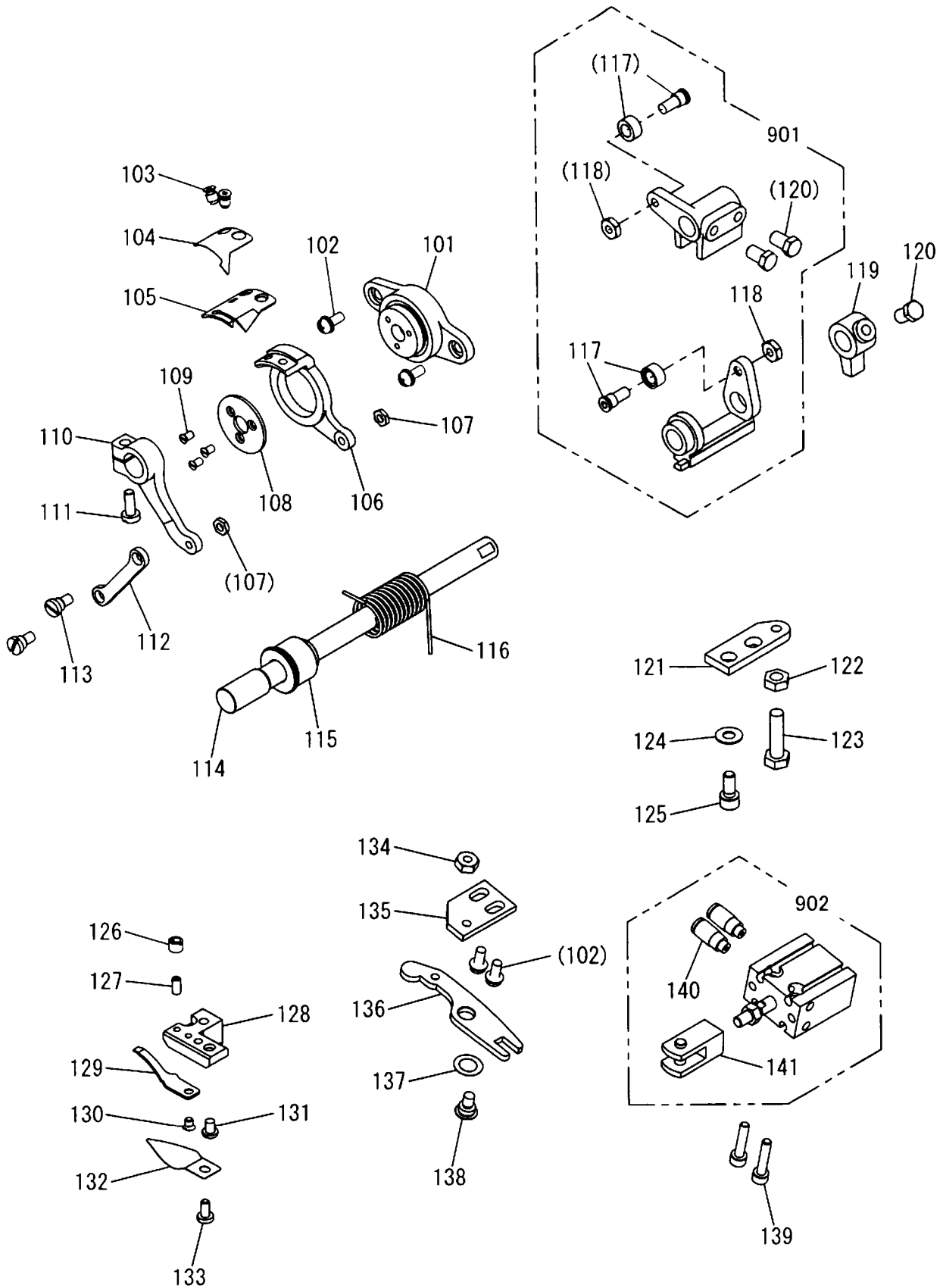

[J]系切り機構

THREAD TRIMMING MECHANISM

Fig no.	変更 Mod.	部品コード Parts no.	品名	Description	数量 Amt. Req.
☆ J 101		MF00A1527	ダイザ	Knife holding bracket saddle	1
J 102		M91056004	SW-PWブラマイナベネジ M4X10	Screw M4X10	4
☆ J 103		M91151010	サラネジ 11/64(40)X7	Screw 11/64(40)X7	2
☆ J 104		MF02A0834	メス(ヒタリ)	Movable knife (left)	1
☆ J 105		MS07A0782	ホコイタ	Guard plate	1
☆ J 106		MS07A0836	メスダイ(ヒタリ)	Knife base (left)	1
☆ J 107		M91107045	ナット 11/64(40)	Nut 11/64(40)	2
☆ J 108		M94006052	サガネ	Washer	1
☆ J 109		M90803010	サラネジ 1/8(44)X6	Screw 1/8(44)X6	3
☆ J 110		MF00A1392	外ウイタ	Knife driving crank	1
☆ J 111		M91117002	マルヒラネジ 11/64(40)X11.4	Screw 11/64(40)X11.4	1
☆ J 112		MF00A8910	リンク	Link	1
☆ J 113		M91111015	ヒラネジダンツキ 11/64(40)X6.2	Screw 11/64(40)X6.2	2
J 114		MH20A0887	メスヨウトウシク	Knife driving shaft	1
J 115		MH20A0892	メスヨウトウシクメタル	Knife driving shaft bushing	1
☆ J 116		MF10A0572	ツルマキバネ	Spring	1
☆ J 117		MF01E0411	コロ・コロシクミタテ	Cam follower. Shoulder screw assy	2
☆ J 118		M91201045	ナット 3/16(28)	Nut 3/16(28)	2
☆ J 119		ME20E0477	ストップパ	Stopper	1
☆ J 120		M91501022	ホルト 15/64(28)X10	Bolt 15/64(28)X10	3
☆ J 121		MF00A1477	ストップパイタ	Stopper plate	1
☆ J 122		M91502045	ナット 15/64(28)	Nut 15/64(28)	1
☆ J 123		M91512022	ホルト 15/64(28)X20	Bolt 15/64(28)X20	1
J 124		M90511050	ミガキサガネ 5	Washer 5	2
J 125		M95002017	セフティソケット M5X12	Safety socket bolt M5X12	2
☆ J 126		M91110045	ナット 9/64(40)	Nut 9/64(40)	1
☆ J 127		M90913001	トメネジ 9/64(40)X8.5	Screw 9/64(40)X8.5	1
☆ J 128		MF00A1603	トリツケダイ	Bracket for fixed blade	1
☆ J 129		MS10A0838	コテイメス	Fixed blade	1
☆ J 130		M90907010	サラネジ 9/64(40)X5	Screw 9/64(40)X5	1
J 131		M91011004	ブラマイナベネジ M4X6	Screw M4X6	1
☆ J 132		MS07A0180	イトアンナイ	Thread guide	1
☆ J 133		M90921002	ヒラネジ 9/64(40)X8	Screw 9/64(40)X8	1
☆ J 134		M91202045	ナット 3/16(28)	Nut 3/16(28)	1
☆ J 135		MS07A1603	トリツケイタ	Adapter	1
☆ J 136		MF00A0391	外ウイタ	Thread trimmer driving lever	1
☆ J 137		ME20A0915	シムリング	Washer	1
☆ J 138		M91212015	ヒラネジダンツキ 3/16(28)X6.5	Screw 3/16(28)X6.5	1
J 139		M94024017	セフティソケット M4X20	Safety socket bolt M4X20	2
☆ J 140		MA20A5571	ワンタッチツキテ	Connector	2
☆ J 141		MA16A0621	ナックル	Knuckle	1
☆ J 901		MB25E0351	カムツイジユウウテクミタテ	Cam follower crank assy	1
☆ J 902		MB61E0434	エアシリンダクミタテ	Air cylinder assy	1

K X-Yテーブル機構
 X-Y TABLE MECHANISM

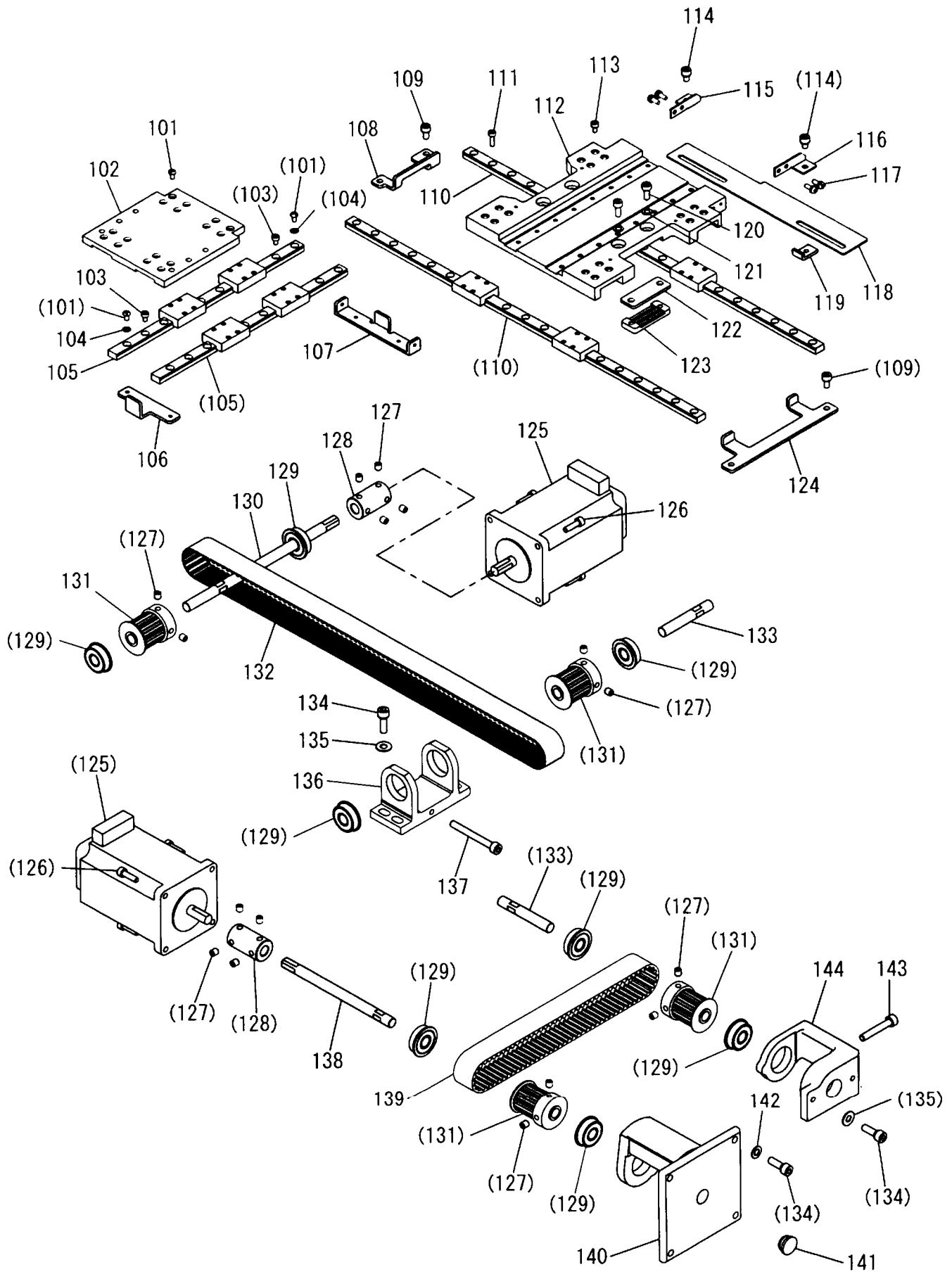

[K]X-Yテーブル機構
X-Y TABLE MECHANISM

Fig no.	変更 Mod.	部品コード Parts no.	品名	Description	数量 Amt. Req.
					20
K 101		M90814004	ブラマイナベネジ M3X5.2	Screw M3X5.2	1
K 102		MH20A0957	Yジクイドウレース	Movable race Y	14
K 103		M93004021	ロッカクアナツキホルト M3X5	Socket bolt M3X5	4
K 104		M90317050	コサガネ 3	Washer 3	2
K 105		MH10A0920	スライドガイド	Slide guide	1
K 106		MH20A0477	Yジクストップ (マエ)	Stopper Y (front)	1
K 107		MH20A1477	Yジクストップ (ウシロ)	Stopper Y (rear)	1
K 108		MH20A2477	Xジクストップ (ヒタリ)	Stopper X (left)	4
K 109		M94002017	セフティソケット M4X8	Safety socket bolt M4X8	2
K 110		MH10A1920	スライドガイド	Slide guide	23
K 111		M95013021	ロッカクアナツキホルト M3X10	Socket bolt M3X10	1
K 112		MH20A1957	Xジクイドウレース	Movable race X	16
K 113		M94003017	セフティソケット M3X6	Safety socket bolt M3X6	2
K 114		M94008017	セフティソケット M4X6	Safety socket bolt M4X6	1
☆ K 115		MB60A1429	ケンシュツハンササイ	Bracket	1
☆ K 116		MB60A0429	ケンシュツハンササイ	Bracket	4
K 117		M90816004	SW-PWブラマイナベネジ M3X8	Screw M3X8	1
K 118		MH20A0407	ケンシュツハン X	Detector plate X	2
☆ K 119		MB60A2601	ケンシュツハントリツケイタ	Bracket	4
K 120		M91060021	ロッカクアナツキホルト M4X10	Socket bolt M4X10	4
K 121		M90422050	コサガネ 4	Washer 4	2
K 122		MH20A3476	ベルトスペース X	Belt spacer X	2
☆ K 123		MB60A0778	ベルトオサエ	Belt clasper	1
K 124		MH20A3477	Xジクストップ (ミキ)	Stopper X (right)	2
K 125		MH10A0848	ステップングモータ	Stepping motor	8
K 126		M94040021	ロッカクアナツキホルト M4X14	Socket bolt M4X14	16
K 127		M94001001	ナイロケットメネジ M5X6	Screw M5X6	2
K 128		ME10A0571	ジクツキテ	Coupring	8
K 129		M91001075	ボールベアリング	Ball bearing	1
K 130		MH20A0390	Xクトウジク	Driving shaft X	4
K 131		MH10A0767	タイミングプーリ	Cog pulley	1
K 132		MH20A0523	タイミングベルト X	Cog belt X	2
K 133		MH10A1454	プーリジク	Pulley shaft	10
K 134		M95004017	セフティソケット M5X16	Safety socket bolt M5X16	6
K 135		M90511050	ミカキサガネ 5	Washer 5	1
K 136		MH10A1758	ブラケット X	Bracket X	1
K 137		M95005021	ロッカクアナツキホルト M5X40	Socket bolt M5X40	1
K 138		MH20A1390	Yクトウジク	Driving shaft Y	1
K 139		MH20A1523	タイミングベルト Y	Cog belt Y	1
K 140		MH20A0758	ブラケット	Bracket	1
K 141		M91304080	ゴムセン φ13	Rubber plug φ13	4
K 142		M90512050	コサガネ 5	Washer 5	1
K 143		M95006021	ロッカクアナツキホルト M5X30	Socket bolt M5X30	1
K 144		MH20A1758	ブラケット	Bracket	1

☆印はPLK-E2010R共通部品を示します。
☆ indicates PLK-E2010R common parts.

L 外押え機構(1)
 WORK HOLDER MECHANISM(1)

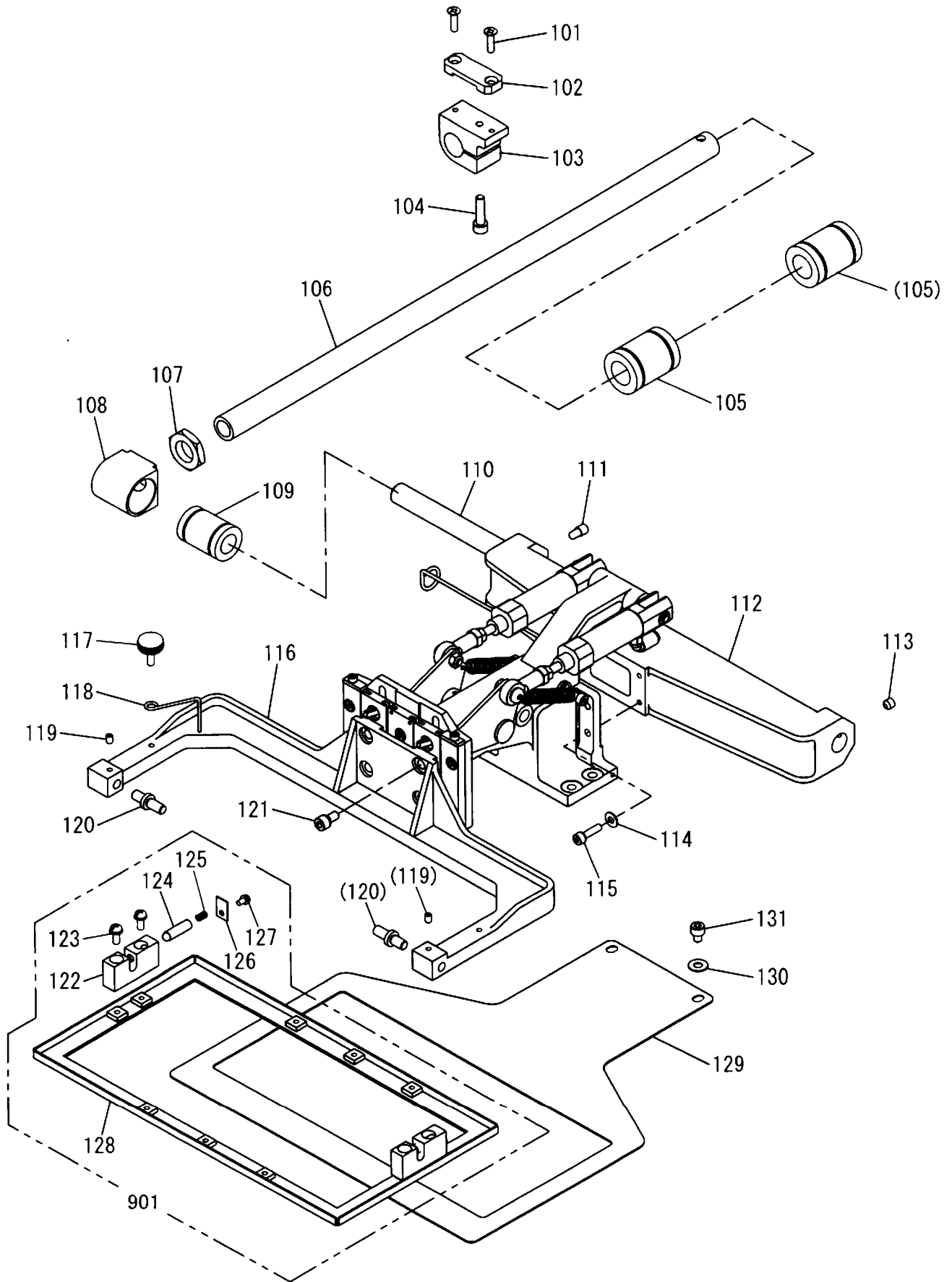

[L]外押え機構(1)
WORK HOLDER MECHANISM(1)

Fig no.	変更 Mod.	部品コード Parts no.	品名	Description	数量 Amt. Req.
L 101		M94001037	Pサラネジ M4X12	Screw M4X12	2
L 102		MH20A0778	ベルトオサエ	Belt clasper	1
☆ L 103		MA20A0781	Yベルトダイ	Y-belt holder	1
L 104		M95001017	セフティソケット M5X20	Safety socket bolt M5X20	1
L 105		MB62A0921	リニアブッシュ	Bearing	2
L 106		MH20A2390	Yクトウシク	Y-drive shaft	1
L 107		M94008045	ロックナット M16X1.0	Nut M16X1.0	1
L 108		MH27A0692	シクウケハウジング	Bearing housing	1
☆ L 109		M96003070	リニアブッシュ	Bearing	1
L 110		MH20A0454	シク	Shaft	1
L 111		M96001005	ロックアナツキメネジホウサキ M6	Screw M6	1
L 112		MH20A1455	シクササエ	Shaft holder	1
L 113		M96002001	ナイロックメネジ M6X6	Screw M6X6	1
L 114		M90421050	ミガキサガネ 4	Washer 4	4
L 115		M94006017	セフティソケット M4X16	Safety socket bolt M4X16	4
L 116		MH20A0273	オサエウテ	Clamp adapter	1
☆ L 117		MA20A0650	ナールドノブ	Knurled knob	1
L 118		MB61A0477	ストップ	Stopper	1
L 119		M91053020	ロックアナツキメネジ M4X6	Screw M4X6	2
☆ L 120		MB62A5454	オサエシク	Clamp stud	2
L 121		M95005017	セフティソケット M5X10	Safety socket bolt M5X10	4
L 122		ME40A0426	ササエ	Support	2
L 123		M91056004	SW-PWプライナヘネジ M4X10	Screw M4X10	4
☆ L 124		M90611060	ピン	Pin	2
☆ L 125		MS13A0572	ツルマキバネ	Spring	2
☆ L 126		MS02B0257	オサエイタ	Holder plate	2
L 127		M90859004	SW-PWプライナヘネジ M3X6	Screw M3X6	2
☆ L 128		MS12A0257	オサエ	Clamp frame	1
L 129		MH20A0272	オクリイタ	Feed plate	1
L 130		M90511050	ミガキサガネ 5	Washer 5	2
L 131		M95052021	ロックアナツキホル M5X6	Socket bolt M5X6	2
L 901		MH20E0105	ソオサエクミタテ	Clamp frame assy	1

M 外押え機構(2)
 WORK HOLDER MECHANISM(2)

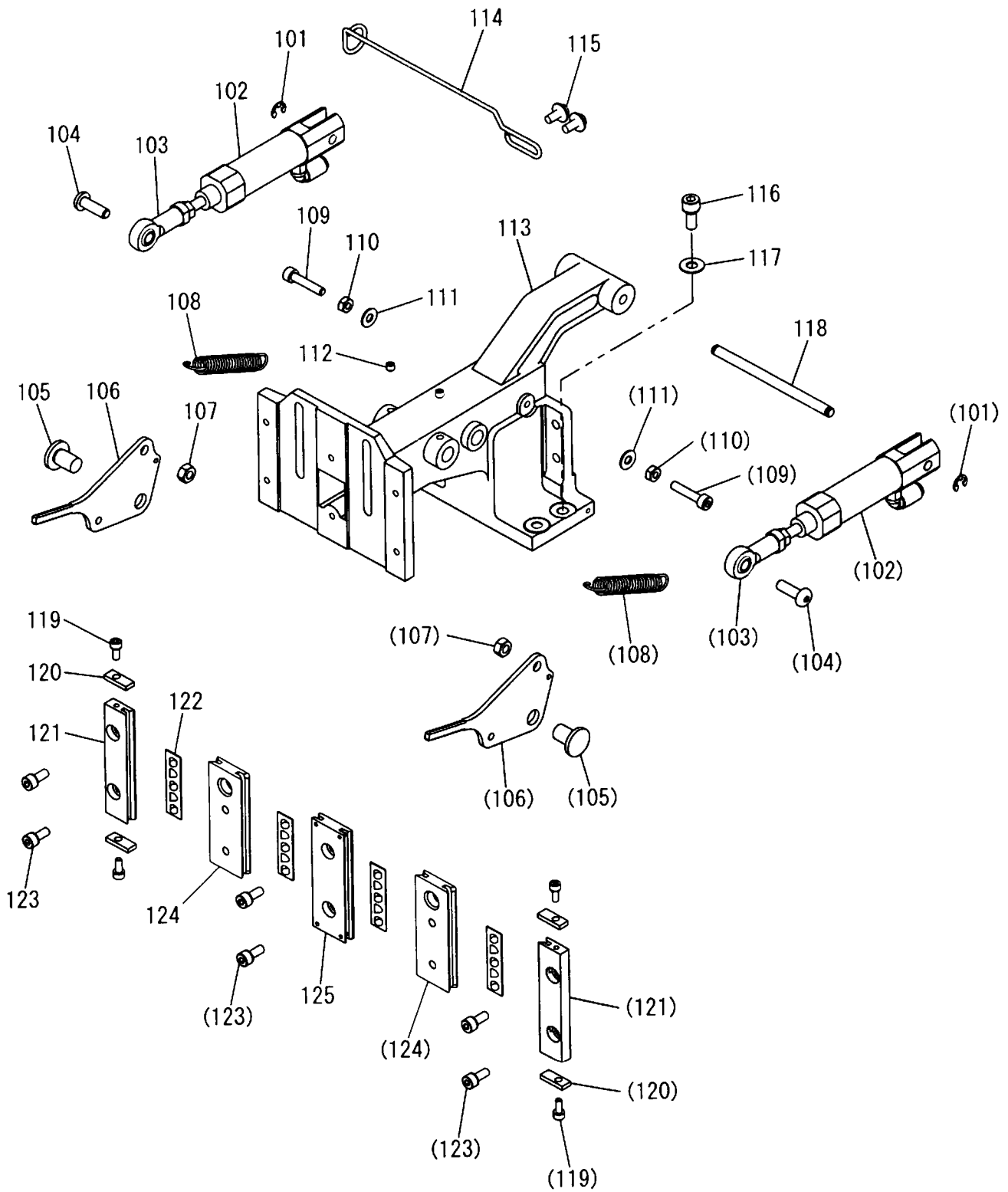

[M]外押え機構(2)
WORK HOLDER MECHANISM(2)

Fig no.	変更 Mod.	部品コード Parts no.	品名	Description	数量 Amt. Req.
M 101		M90504065	Eカ'外ワ'4	E-type retaining ring 4	2
M 102		MB62A1434	エアシリンダ (ワンタッチキツキ)	Air cylinder (with quick joint)	2
☆ M 103		MB62A0975	ロッド'エンド	Connecting link	2
M 104		M95037021	ロッカク'ア'ナツキボ'ルト M5X16	Bolt M5X16	2
☆ M 105		MB61A3454	ツバ'ツ'キシク	Shaft	2
M 106		MH20A0266	オサ'エ'レバ'ー	Pushing lever	2
M 107		M91382045	ナ'ット M5	Nut M5	2
M 108		MH20A0572	ツル'マ'キハ'ネ	Spring	2
M 109		M94015021	ロッカク'ア'ナツキボ'ルト M4X20	Socket bolt M4X20	2
M 110		M91007045	ナ'ット M4	Nut M4	2
M 111		M90421050	ミ'ガ'キ'ザ'ガ'ネ 4	Washer 4	2
M 112		M91055020	ロッカク'ア'ナツキ'メ'ネ'ジ M4X4	Screw M4X4	2
M 113		MH20A0308	オサ'エ'タ'イ	Clamp bracket	1
M 114		MB62A0707	ハン'ガ'ー	Hanger	1
M 115		M91013004	SW-MW'プ'ラ'マイ'ナ'ヘ'ネ'ジ M4X10	Screw M4X10	2
M 116		M95002017	セ'フ'テ'イ'ソ'ケ'ット M5X12	Safety socket bolt M5X12	4
M 117		M90511050	ミ'ガ'キ'ザ'ガ'ネ 5	Washer 5	4
☆ M 118		M90531060	ピ'ン	Pin	1
M 119		M94003017	セ'フ'テ'イ'ソ'ケ'ット M3X6	Safety socket bolt M3X6	4
☆ M 120		MB62A6477	ス'ト'ッ'パ	Stopper	4
M 121		MB62A0957	オサ'エ'コ'テ'イ'レ'ース	Fixed race	2
☆ M 122		M94008070	ロ'ー'ラ'ー'リ'テ'ー'ナ	Slide bearing	4
M 123		M94001017	セ'フ'テ'イ'ソ'ケ'ット M4X10	Safety socket bolt M4X10	6
M 124		MB62A1957	オサ'エ'ト'ウ'レ'ース	Movable race	2
M 125		MH20A2957	オサ'エ'コ'テ'イ'レ'ース	Fixed race	1

□ N ワイパー機構
WIPER MECHANISM

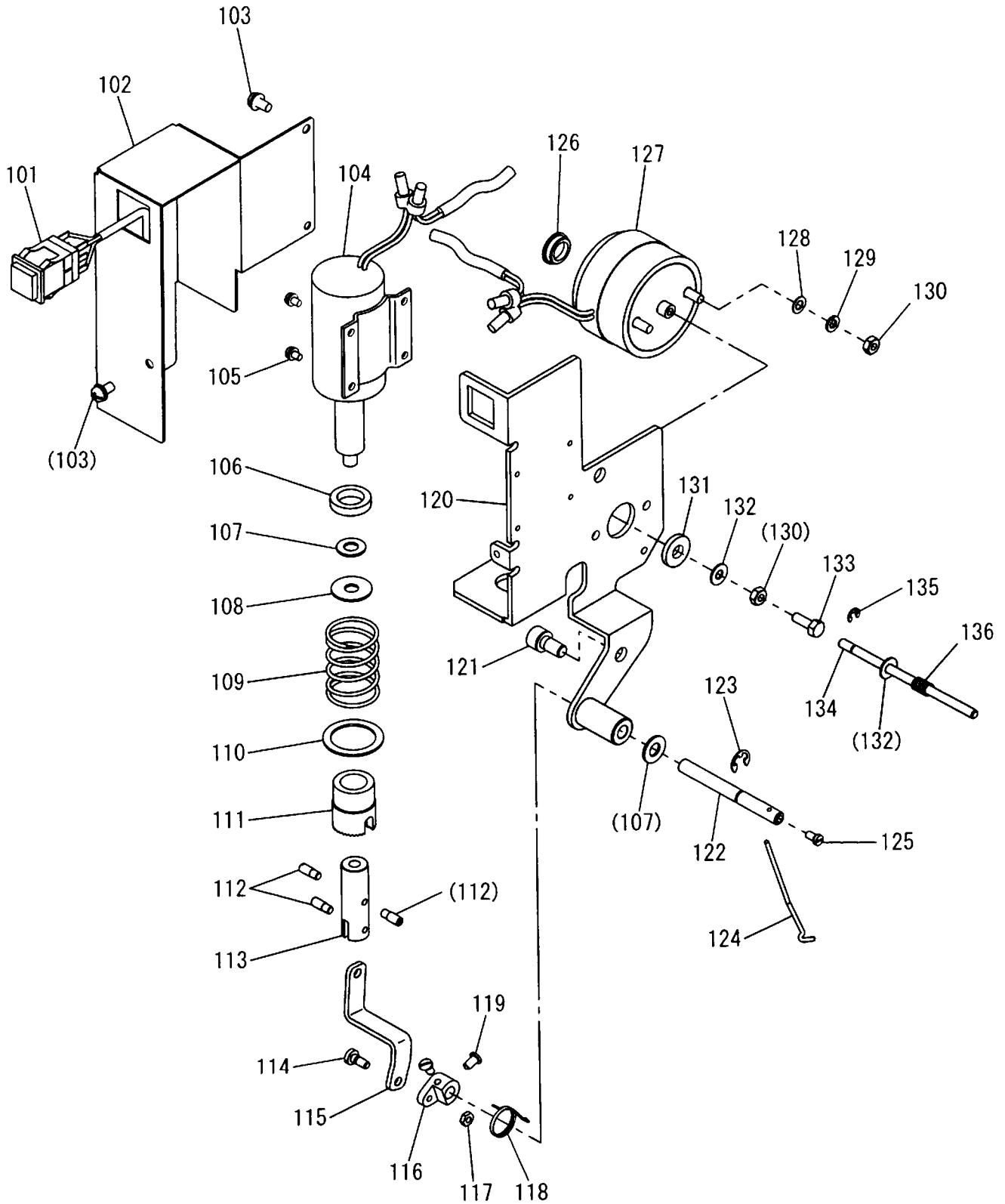

[N]ワイパー機構
WIPER MECHANISM

Fig no.	変更 Mod.	部品コード Parts no.	品名	Description	数量 Amt. Req.
N 101		MH20E0270	オシホタンスイッチクミ	Stop switch assy	1
N 102		MH10A7339	カバー	Cover	1
N 103		M91054004	SW-PWブラマイナヘネジ M4X8	Screw M4X8	3
N 104		MH20E0519	ワイパソレノイドクミ	Wiper solenoid assy	1
N 105		M90865004	SW-PWブラマイナヘネジ M3X5	Screw M3X5	4
N 106		MH10A1417	ゴムワ	Rubber cushion	1
N 107		M90631050	ミガキサガネ 6	Washer 6	2
N 108		M90634050	サガネ	Washer	1
N 109		MH10A0700	ハネ	Spring	1
N 110		MH10A0915	リング	Ring	1
N 111		MH10A5477	ストップパ	Stopper	1
N 112		M90910033	ピンネジ 9/64(40)X4	Screw 9/64(40)X4	3
N 113		MH10A0571	ツキテ	Connector	1
N 114		M90932015	ヒラネジタンツキ 9/64(40)X9	Screw 9/64(40)X9	1
N 115		MH10A6910	リンク	Thread wiper connecting rod	1
N 116		MH10A0981	ワイパーウテ	Wiper adapter	1
N 117		M90901045	ナット 9/64(40)	Nut 9/64(40)	1
N 118		MH10A0729	ヒネリハネ	Spring	1
N 119		M90908003	マルヒラネジ 9/64(40)X6	Screw 9/64(40)X6	2
N 120		MH10A5601	ワイパートリツケイタ	Wiper setting plate	1
N 121		M96002017	セフティソケット M6X12	Safety socket bolt M6X12	2
N 122		MH10A1530	ワイパーシャク	Wiper shaft	1
N 123		M90505065	Eガ外メワ 5	E-type retaining ring 5	1
N 124		MH10A0980	ワイパー	Wiper	1
N 125		M90806002	ヒラネジ 1/8(44)X6	Screw 1/8(44)X6	1
N 126		M91305080	ゴムセン φ13	Rubber plug φ13	1
N 127		MH20E1519	イトユルメソレノイドクミ	Thread release solenoid assy	1
N 128		M90422050	コサガネ 4	Washer 4	2
N 129		M90424053	ハネサガネ 4	Spring washer 4	2
N 130		M91007045	ナット M4	Nut M4	3
N 131		M96010052	サガネ	Washer	1
N 132		M90421050	ミガキサガネ 4	Washer 4	2
N 133		M91005022	ロツカクホルト M4X12	Hexagon head bolt M4X12	1
N 134		M90434060	ピン	Pin	1
N 135		M90512065	Eガ外メワ 3	E-type retaining ring 3	1
N 136		MH10A1701	ハネ	Spring	1

P 給油機構
OIL LUBRICATION MECHANISM

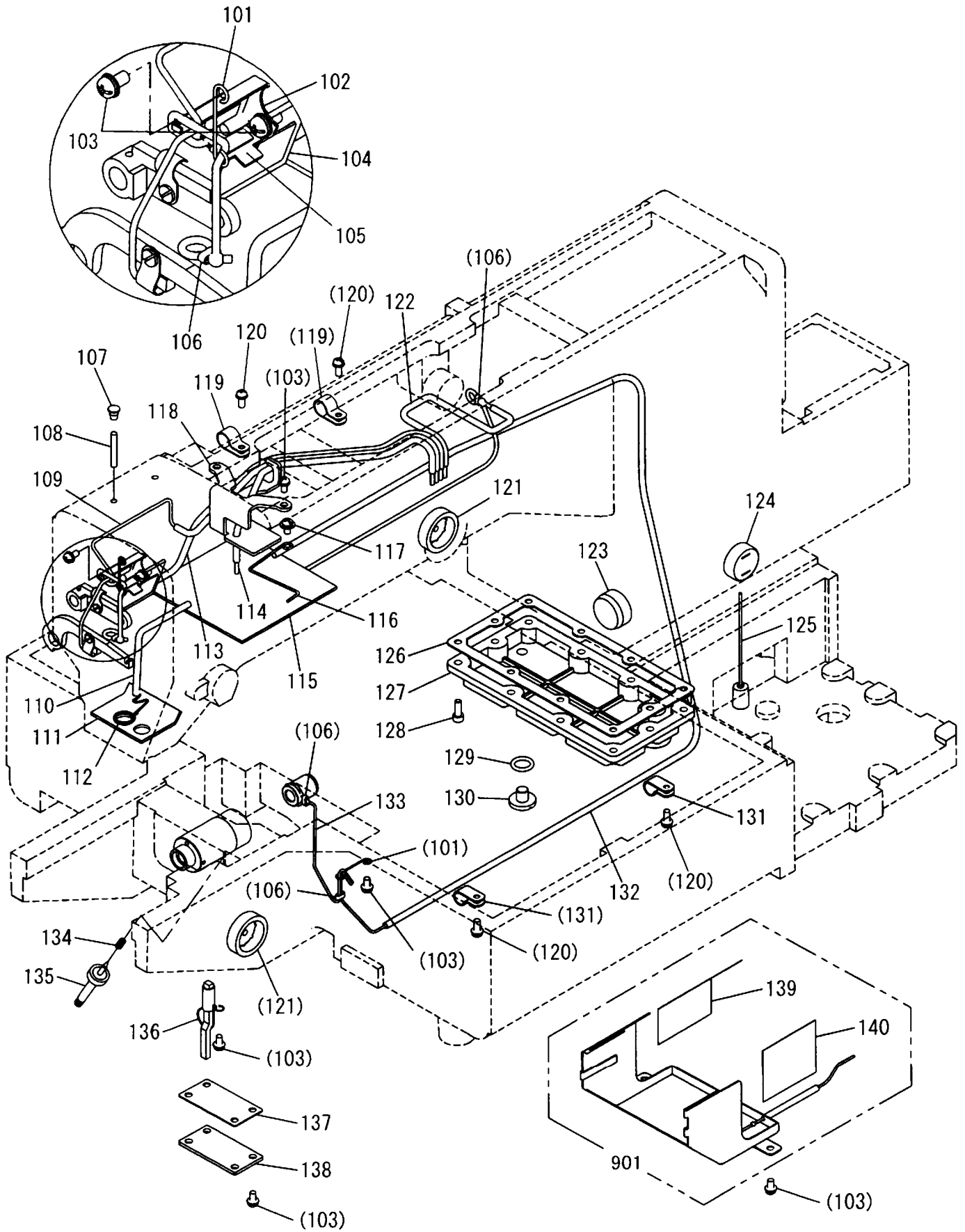

[P]給油機構

OIL LUBRICATION MECHANISM

Fig no.	変更 Mod.	部品コード Parts no.	品名	Description	数量 Amt. Req.
☆ P 101		MS03A2780	ホルダ	Holder	2
P 102		MH27A2780	ホルダ	Holder	1
P 103		M91054004	SW-PWブライナヘネジ M4X8	Screw M4X8	12
P 104		MH10A6740	フェルト	Felt	1
P 105		MH10A5740	フェルト	Felt	1
☆ P 106		MF80A0780	ホルダ	Holder	3
P 107		M90573080	ゴムセン φ5.7	Rubber plug φ5.7	2
P 108		MP40A1740	フェルト	Felt	2
P 109		MH20E0688	パイプヒモクミ (ナカオサエ)	Oil pipe assy (presser foot)	1
P 110		MH27E3688	パイプヒモクミ (カンユ)	Oil pipe assy (circulation)	1
P 111		MH10A7740	フェルト	Felt	1
☆ P 112		MF00A2780	ホルダ	Holder	1
P 113		MH20E1688	パイプヒモクミ (ハリホウ)	Oil pipe assy (needle bar)	1
P 114		MH20E2688	パイプヒモクミ (ヘンシンリン)	Oil pipe assy (eccentric cam)	1
P 115		MH20A0740	フェルト	Felt	1
P 116		ME18A2780	ホルダ	Holder	1
P 117		M91071004	SW-MWブライナヘネジ M4X8	Screw M4X8	1
P 118		MH27A0780	ホルダ	Holder	1
P 119		M94007099	ナイロンクリップ AB-6N	Nylon clip AB-6N	2
P 120		M91056004	SW-PWブライナヘネジ M4X10	Screw M4X10	4
☆ P 121		MN10A0135	アブラマト	Oil gauge	2
P 122		MH20E3688	パイプヒモクミ (ナカオサエメタル)	Oil pipe assy (presser foot bushing)	1
P 123		MH27A0500	ゴムセン φ25	Rubber plug φ25	1
P 124		MF13A0135	アブラマト	Oil gauge	1
P 125		MH27A0225	ウキコクミタテ	Floater	1
P 126		MH27A0691	ソコフタカスケット	Gasket for bottom cover	1
P 127		MH27A0516	ソコフタ	Bottom cover	1
P 128		M94003021	ロックアナツキホルト M4X12	Socket bolt M4X12	10
P 129		M91101085	リング	O-ring	1
P 130		M92004002	ヒラネジ 5/16(24)X8	Screw 5/16(24)X8	1
P 131		MN60A0620	ナイロンクリップ AB-5N	Nylon clip AB-5N	2
P 132		MH20E4688	パイプヒモクミ (カンユ)	Oil pipe assy (circulation)	1
P 133		MH20E5688	パイプヒモクミ (シタジクメタル)	Oil pipe assy (hook shaft bushing)	1
☆ P 134		MG30A0700	ツルマキバネ	Spring	1
P 135		M91008035	ユリウチヨウセツネジ	Oil adjusting screw	1
P 136		MH27E5688	パイプフェルトクミタテ	Oil pipe complete	1
☆ P 137		MS10A1691	カスケット	Gasket	1
☆ P 138		MS10A1742	アブラフタ	Cap	1
P 139		MH27A0797	ホウユフィルムヒタリ	Oil cover film (L)	1
P 140		MH27A1797	ホウユフィルムミキ	Oil cover film (R)	1
P 901		MH20A6339	オイルカバークミタテ	Oil cover assy	1

Q 配線・配管関係

CABLE COMPONENT & PNEUMATIC CONTROL UNIT

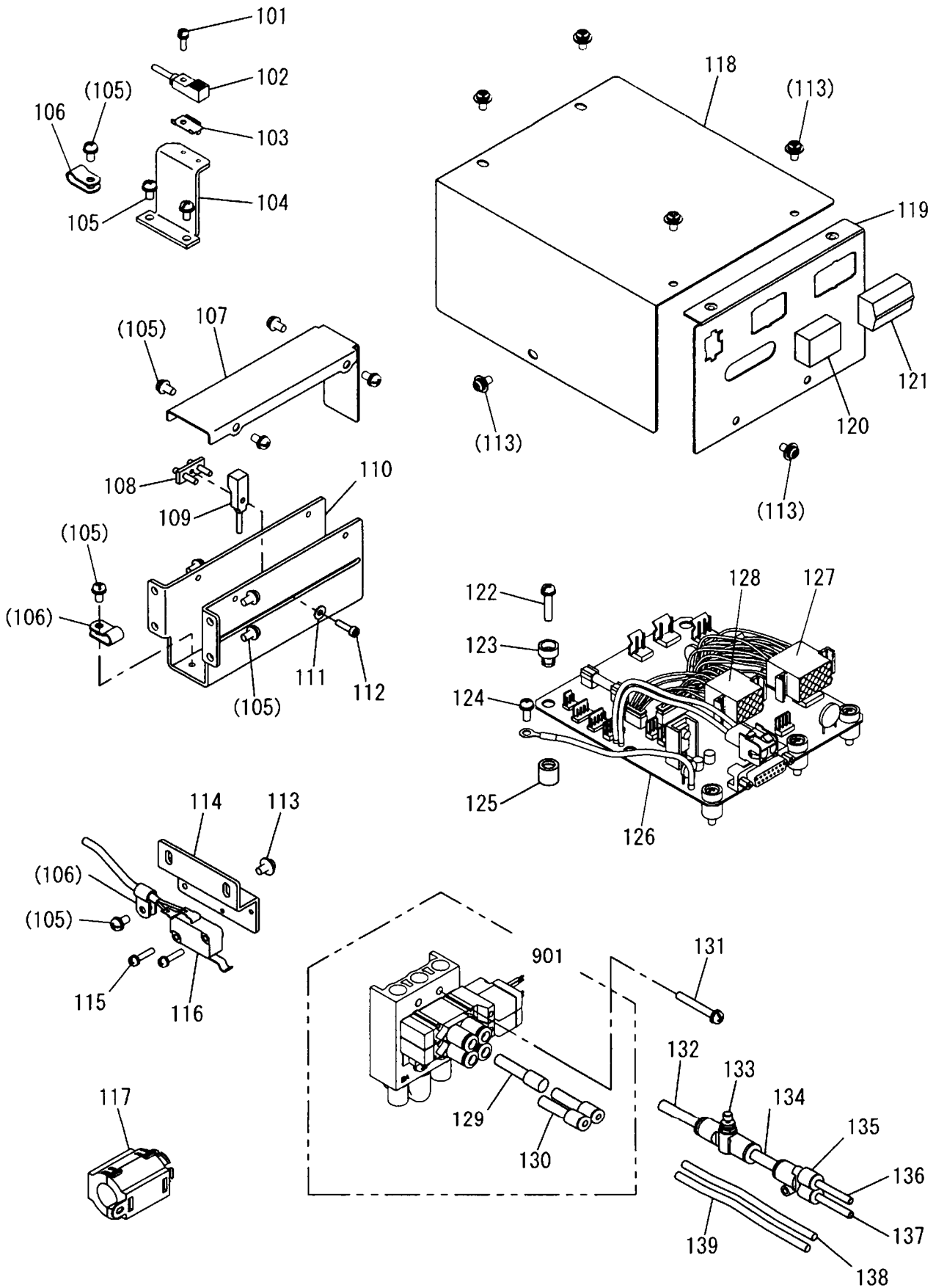

[Q]配線・配管関係

CABLE COMPONENT & PNEUMATIC CONTROL UNIT

Fig no.	変更 Mod.	部品コード Parts no.	品名	Description	数量 Amt. Req.
Q 101		M91606022	ロツクアナツキボルト M3X10	Bolt M3X10	1
Q 102		MH10A1501	キンセツスイッチ X	Detector X	1
Q 103		MH10A0602	トリツケカナゲ	Holder	1
Q 104		MH20A0408	ケンシュツダイ X	Detector bracket X	1
Q 105		M91054004	SW-PWブラマイナベネジ M4X8	Screw M4X8	13
Q 106		M94003099	ナイロンクリップ AB-3N	Nylon clip AB-3N	3
☆ Q 107		ME20A0339	Yケンシュツキカバー	Detector cover Y	1
☆ Q 108		ME10A2780	ネジイタクミタテ	Holder plate assy	1
Q 109		MH27E2484	キンセツスイッチ Y	Detector Y	1
☆ Q 110		ME20A0408	Yケンシュツダイ	Detector bracket Y	1
Q 111		M90316050	ミガキサガネ 3	Washer 3	1
Q 112		M93011021	ロツクアナツキボルト M3X12	Socket bolt M3X12	1
Q 113		M91071004	SW-MWブラマイナベネジ M4X8	Screw M4X8	9
Q 114		MH10A9601	スイッチトリツケイタ	Micro switch bracket	1
Q 115		M90864004	SW-PWブラマイナベネジ M3X14	Screw M3X14	2
Q 116		MH27E3484	マイクロスイッチクミタテ	Micro switch assy	1
Q 117		K14M19400102	フェライトコア	Ferritic core	1
Q 118		MH27B1339	Pハンカバー	Print circuit board cover	1
Q 119		MH27A2601	コネクタトリツケイタ	Connector panel	1
Q 120		MH10B2339	ダスターカバー	Duster cover	1
Q 121		MH10B1339	ダスターカバー	Duster cover	1
Q 122		M91057004	SW-PWブラマイナベネジ M4X20	Screw M4X20	5
☆ Q 123		MB60A0366	ワシタツチブツシュ	Nylon bush	5
Q 124		M90409037	SW-PW Pナベネジ M4X10	Screw M4X10	1
☆ Q 125		MB60A2352	ワシタツチブツシュ	Nylon bush	5
Q 126		M800G2SOL	ソレノイドキバン PLK-G2-SOL	Print circuit board PLK-G2-SOL	1
Q 127		MH10A3508	セツブクデンセンクミタテ 15P	Connecting cable assy 15P	1
Q 128		MH10A4508	セツブクデンセンクミタテ 12P	Connecting cable assy 12P	1
☆ Q 129		MB62A0757	プラグ	Plug	1
Q 130		MA30A0964	レジュサ	Reducer	2
Q 131		M91276004	SW-PWブラマイナベネジ M4X30	Screw M4X30	4
Q 132		MH20A0567	チューブ	Tube	1
☆ Q 133		MA16A0495	スピードコントローラ	Speed controler	1
Q 134		MH20A1567	チューブ	Tube	1
☆ Q 135		MA20A6571	イケイニオン Y	Connector	1
Q 136		MH20A2567	チューブ	Tube	1
Q 137		MH20A3567	チューブ	Tube	1
Q 138		MH20A4567	チューブ	Tube	1
Q 139		MH20A5567	チューブ	Tube	1
Q 901		MH27E0599	デンジベンクミタテ	Solenoid valve complete	1

☆印はPLK-E2010R共通部品を示します。

☆ indicates PLK-E2010R common parts.

☐ テーブル関係
TABLE & STAND

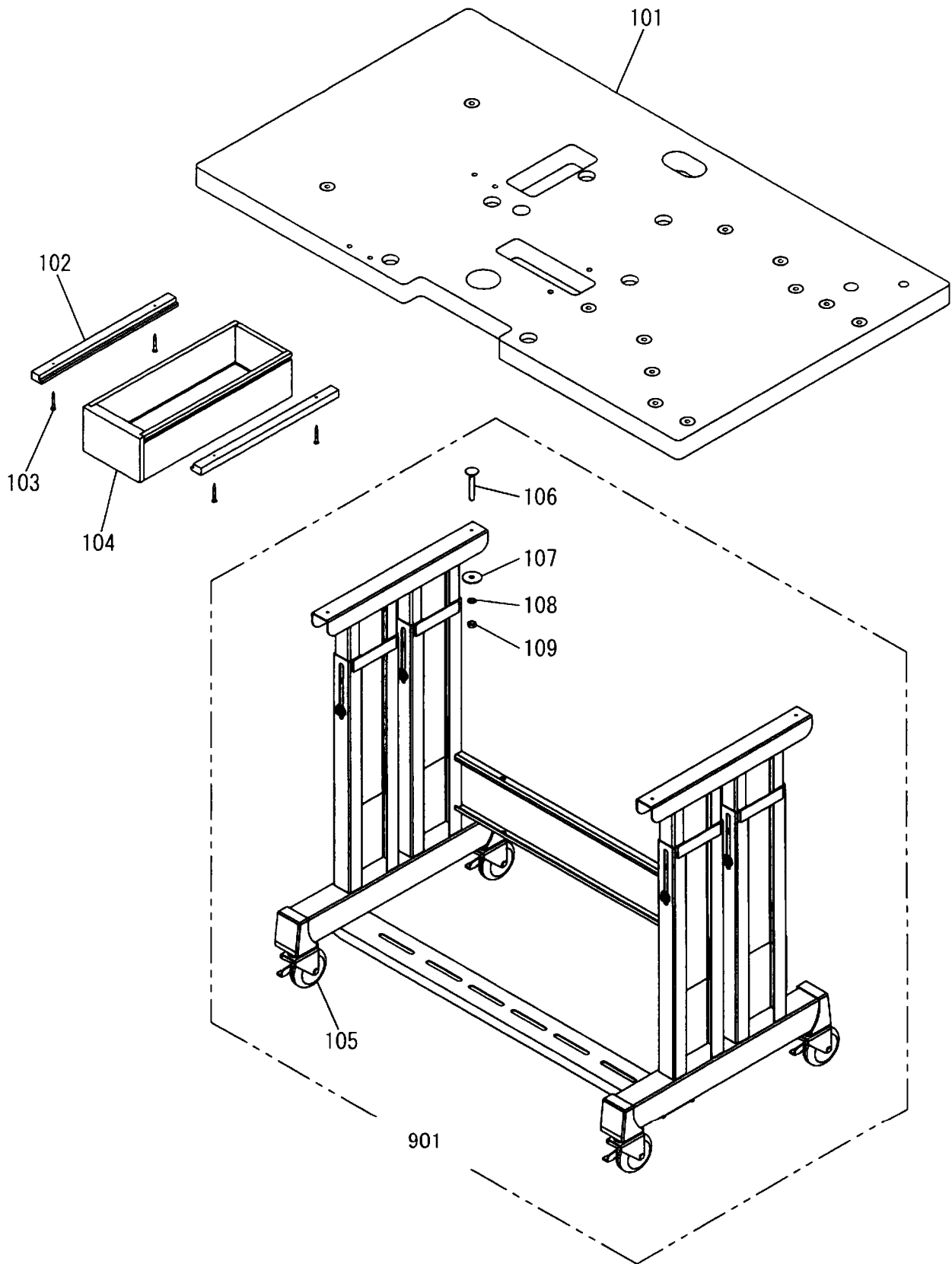

[R]テーブル関係
TABLE & STAND

Fig no.	変更 Mod.	部品コード Parts no.	品名	Description	数量 Amt. Req.
R 101		MH20A0595	テニタ	Table top	1
☆ R 102		MB60A3957	レール	Rail	2
☆ R 103		M90406040	Pサラモクネジ φ4.5X38	Wooden screw φ4.5X38	4
☆ R 104		MB60A0719	ヒキダシ	Drawer	1
☆ R 105		MB60A1368	キャスター	Caster	4
☆ R 106		K14M90451401	トリツケボルト M8X60	Mounting bolt M8X60	4
☆ R 107		M90710050	トクショサガネ 8	Special washer 8	4
R 108		M90802053	バネサガネ 8	Spring washer 8	4
R 109		M92008045	ナット M8	Nut M8	4
R 901		MH27E0150	キャクミタテ	Leg assy	1

S 付属品(1)
 ACCESSORIES(1)

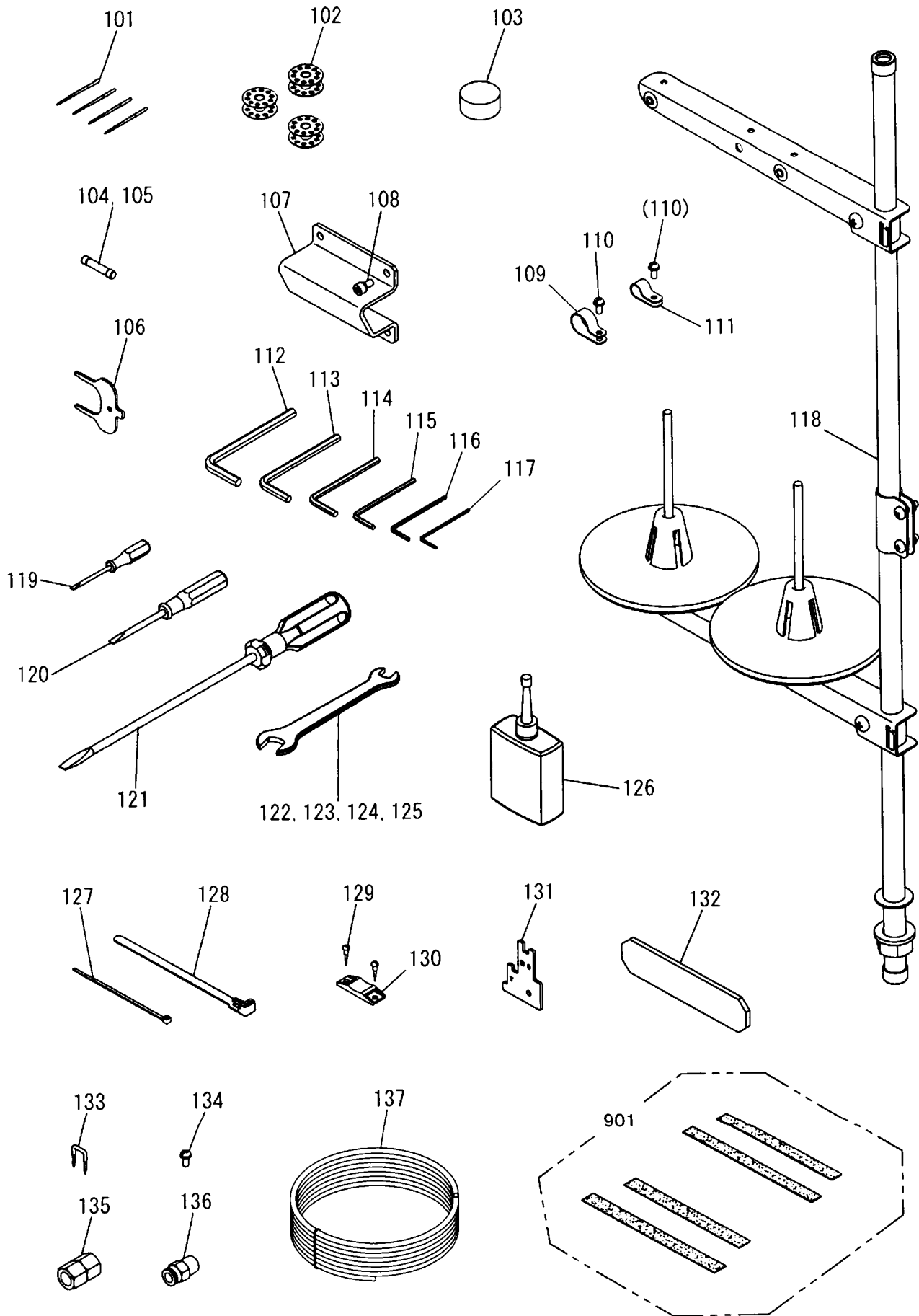

[S] 付属品(1)

ACCESSORIES(1)

Fig no.	変更 Mod.	部品コード Parts no.	品名	Description	数量 Amt. Req.
☆ S 101		MS02A0128	ミシンハリ DPX17#18	Needle DPX17#18	4
☆ S 102		MF25B0123	ホビーン	Bobbin	3
S 103		MH10A0419	ホウシソコム	Rubber cushion	6
S 104		MH10A3FUS	ヒューズ 2.5A	Fuse 2.5A	1
S 105		MH10A2FUS	ヒューズ 20A	Fuse 20A	1
S 106		MF17A0565	カクテョウセイグ	Speed command disk adjusting plate	1
S 107		MH10A0613	トウフササイ	Head rest	1
S 108		M95005017	セフテイソケット M5X10	Safety socket bolt M5X10	4
☆ S 109		MB60A2620	ナイロンクリップ AB-10N	Nylon clip AB-10N	1
S 110		M91056004	SW-PW プラマイナネジ M4X10	Screw M4X10	2
☆ S 111		MB60A1620	ナイロンクリップ AB-8N	Nylon clip AB-8N	1
☆ S 112		MS05A1976	ロツカクホウレンチ 6	Hexagonal wrench 6	1
☆ S 113		MS05A0976	ロツカクホウレンチ 5	Hexagonal wrench 5	1
☆ S 114		MS01A1976	ロツカクホウレンチ 4	Hexagonal wrench 4	1
☆ S 115		MS02A2976	ロツカクホウレンチ 3	Hexagonal wrench 3	1
☆ S 116		MS02A1976	ロツカクホウレンチ 2.5	Hexagonal wrench 2.5	1
☆ S 117		MS02A0976	ロツカクホウレンチ 2	Hexagonal wrench 2	1
S 118		MH10E0193	イタテダイクミタテ	Cotton stand assy	1
☆ S 119		MB02A1608	ドライバー (ショウ)	Screw driver (small)	1
☆ S 120		MB02A0608	ドライバー (チュウ)	Screw driver (middle)	1
☆ S 121		MF00A0608	ドライバー (ダイ)	Screw driver (large)	1
☆ S 122		MS02A0479	スパナ 13-17	Spanner 13-17	1
☆ S 123		MM11A1479	スパナ 10-14	Spanner 10-14	1
☆ S 124		MS10A1976	スパナ 8-9	Spanner 8-9	1
☆ S 125		MS10A2976	スパナ 6-7	Spanner 6-7	1
☆ S 126		MF10A0149	アブラサシ	Oiler	1
☆ S 127		MF06A1620	インシュロックタイ	Cord tie	1
☆ S 128		MB60A0201	インシュロックタイ	Cord tie	3
☆ S 129		M90306041	マルモクネジ 3.1X16	Wooden screw 3.1X16	6
☆ S 130		MB60A0420	コテイク	Tie holder	3
S 131		MH27A0409	ウワイチゲージ	Up position gauge	1
S 132		MH27A6476	スパーサ	Spacer	1
☆ S 133		M90001043	ステッブル	Staple	6
S 134		M90409037	SW-PW プナネジ M4X10	Screw M4X10	1
☆ S 135		M91010089	ロツカクソケット	Socket	1
☆ S 136		MA30A0571	ワンタッチツキテ	Quickjoint	1
☆ S 137		MS06A0567	エアチューブ	Air tube	1
☆ S 901		MB61E4691	ハッキンセット	Clamp pad set	1

T 付属品(2)
ACCESSORIES(2)

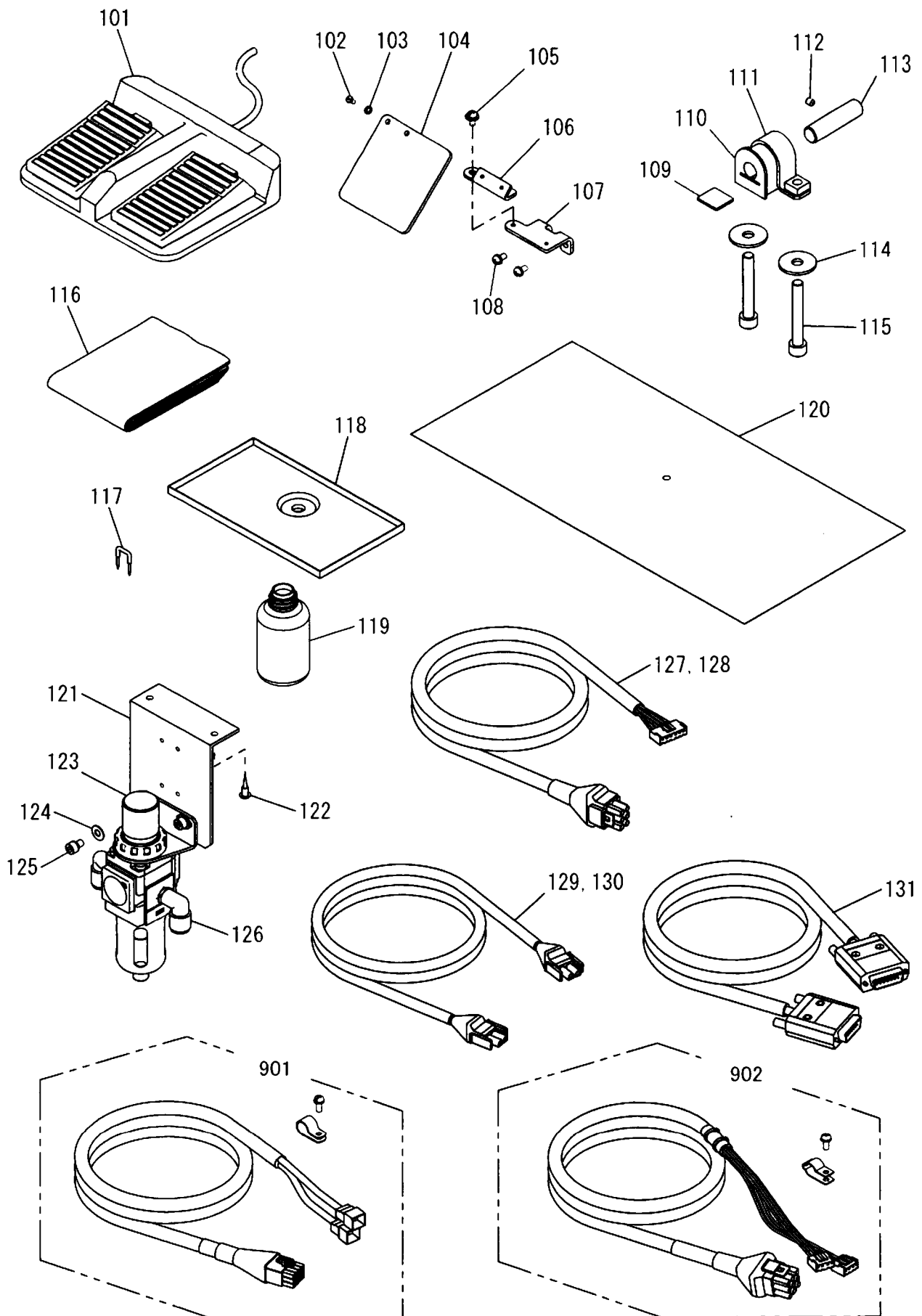

[T] 付属品(2)
ACCESSORIES(2)

Fig no.	変更 Mod.	部品コード Parts no.	品名	Description	数量 Amt. Req.
☆ T 101		M860A0FSW	フットスイッチ	Foot switch	1
T 102		M90806002	ヒラネジ 1/8(44)X6	Screw 1/8(44)X6	2
T 103		M90317050	コサガネ 3	Washer 3	2
T 104		MH10A0160	アイガード	Eye guard	1
T 105		M91071004	SW-MWプライナネジ M4X8	Screw M4X8	3
T 106		MH10A7601	アイガードトリツケイタ	Eye guard bracket	1
T 107		MH10A8601	トリツケイタ	Mounting plate	1
T 108		M91054004	SW-PWプライナネジ M4X8	Screw M4X8	2
T 109		MH10A0435	ジジイタ	Support plate	2
T 110		MH10A0418	ヒンジゴム	Hinge rubber	2
T 111		MH10A0770	ヒンジベース	Hinge base	2
T 112		M95002020	ロッカアナツキメネジ M5X6	Screw M5X6	2
T 113		MH10A7454	ヒンジシク	Hinge shaft	2
T 114		M90835050	ワッシャ	Washer	4
T 115		M98087021	ロッカアナツキホルト M8X55	Socket bolt M8X55	4
☆ T 116		MA20A0734	ビニルカバー	Polyethylene cover	1
☆ T 117		M90001043	ステップル	Staple	4
T 118		MH27A0131	アブラウケ	Oil pan	1
☆ T 119		MF20A0130	アブラビン	Oil bottle	1
☆ T 120		MB61A0797	ホゴフィルム	Film sheet	1
☆ T 121		MB61A5601	レギュレータトリツケイタ	Filter regulator adapter	1
☆ T 122		M90409041	マルモクネジ 4.5X20	Screw 4.5X20	2
☆ T 123		ME40A0963	フィルタレギュレータ (ステーツキ)	Filter regulator	1
T 124		M90511050	ミガキサガネ 5	Washer 5	2
T 125		M95003017	セフティソケット M5X8	Safety socket bolt M5X8	2
☆ T 126		MA20A8571	Lガタツキテ	L-type quick joint	1
T 127		MH10A1508	ケーブル (PFモータ)	Cable (PF motor)	*
T 128		MH20A0508	ケーブル (PFモータ) CEヨウ	Cable (PF motor) for CE	*
T 129		MH10A2508	ケーブル (SOLキバンデンゲン)	Cable (SOL power)	*
T 130		MH27A1508	ケーブル (SOLキバンデンゲン) CEヨウ	Cable (SOL power) for CE	*
☆ T 131		M97320099	ケーブル (SOLキバンシンゴウ)	Cable (SOL signal pulse)	1
T 901		MH10E5508	XYエンコーダケーブルセット	XY encoder cable set	1
T 902		MH10E3508	XYモータケーブルセット	XY motor cable set	1

注) パーツナンバーT127~T130は、ご利用地域により付属形態が異なります。

Remarks) For part No.T127~T130, an attached form is different according to the region.

ご利用地域	EC諸国を除く地域	EC諸国
Region	xcept EC	EC nations
T127	1	-
T128	-	1
T129	1	-
T130	-	1

U オプションパーツ
OPTION PARTS

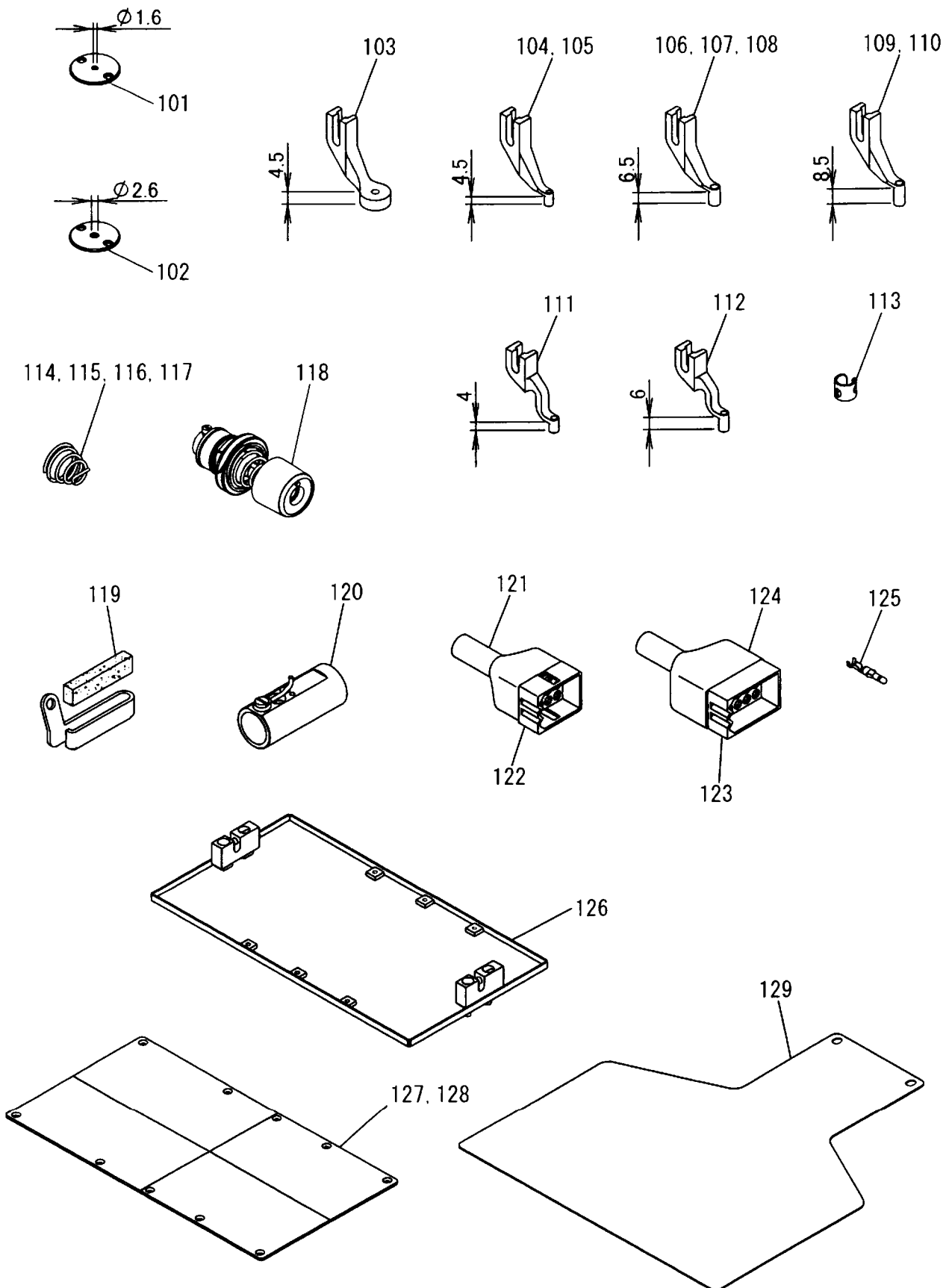

[U]オプションパーツ
OPTION PARTS

Fig no.	変更 Mod.	部品コード Parts no.	品 名	Description	数量 Amt. Req.
☆ U 101		MS02A0101	ハリイタ φ1.6	Needle plate φ1.6	1
☆ U 102		MS02A2101	ハリイタ φ2.6	Needle plate φ2.6	1
☆ U 103		MV35A0106	サラオサエ φ3	Presser foot φ3	1
U 104		MV30A0256	ナカオサエ φ3	Presser foot φ3	1
U 105		MV30A1256	ナカオサエ φ2	Presser foot φ2	1
U 106		MB10M0256	ナカオサエ φ3.3	Presser foot φ3.3	1
☆ U 107		MS03A0256	ナカオサエ φ3	Presser foot φ3	1
☆ U 108		MS03A1256	ナカオサエ φ2	Presser foot φ2	1
☆ U 109		MA35A0256	ナカオサエ φ3	Presser foot φ3	1
☆ U 110		MA35A1256	ナカオサエ φ2	Presser foot φ2	1
U 111		MA21A0256	ナカオサエ φ2.5	Presser foot φ2.5	1
U 112		MA21A1256	ナカオサエ φ2.5	Presser foot φ2.5	1
U 113		MG42A0181	イトアンナイ (アツモ/ヨウ)	Thread guide (for heavy)	1
☆ U 114		MN10A3245	インスイハネ φ1X11	Spring φ1X11	1
U 115		MF23C0245	インスイハネ φ1.6X11	Spring φ1.6X11	1
U 116		MN52A1245	インスイハネ φ1.2X13	Spring φ1.2X13	1
U 117		MS10A0245	インスイハネ φ1X13.5	Spring φ1X13.5	1
U 118		MH10E1210	チヨウセツキクミタテ	Thread tension regulator assy	1
☆ U 119		MS03A0181	イトアンナイ	Thread guide	1
☆ U 120		MS10A0180	イトアンナイ	Thread guide	1
U 121		K14M94319012	コネクタ 12P	Connector 12P	1
U 122		K14M96821809	ナイロンキャップ 12P	Nylon cap 12P	1
U 123		K14M94319015	コネクタ 15P	Connector 15P	1
U 124		K14M96822602	ナイロンキャップ 15P	Nylon cap 15P	1
U 125		K14M77014710	ターミナル	Terminal	1
U 126		MB61E1105	ソトサエクミタテ (アナナシ)	Clamp frame complete (blank)	1
☆ U 127		MB61A0762	ナカオサエイト (2T,ケガキセンアリ)	Clamp plate (with line)	1
☆ U 128		MB61A1762	ナカオサエイト (2T,ケガキセンナシ)	Clamp plate	1
U 129		MH20A1272	オクリイタ (アナナシ)	Feed plate (blank)	1

索引
INDEX-1

部品コード Parts No.	ページ Page	Fig No.	部品コード Parts No.	ページ Page	Fig No.	部品コード Parts No.	ページ Page	Fig No.	部品コード Parts No.	ページ Page	Fig No.
K14M19400102	... P29	... Q 117	M90632050	... P15	... H 104	M91053020	... P21	... L 119	M91606001	... P9	... E 141
K14M77014710	... P37	... U 125	M90634050	... P25	... N 108	M91054004	... P3	... B 106	↑	... P11	... F 102
K14M90451401	... P31	... R 106	M90710050	... P31	... R 107	↑	... P5	... C 129	↑	... P15	... H 144
K14M94319012	... P37	... U 121	M90800086	... P11	... F 125	↑	... P25	... N 103	M91606022	... P29	... Q 101
K14M94319015	... P37	... U 123	M90802053	... P31	... R 108	↑	... P27	... P 103	M91609020	... P9	... E 110
K14M96821809	... P37	... U 122	M90803010	... P17	... J 109	↑	... P29	... Q 105	M91610046	... P5	... C 144
K14M96822602	... P37	... U 124	M90804086	... P11	... F 132	↑	... P35	... T 108	M91650020	... P9	... E 116
M70535065	... P5	... C 105	M90806002	... P25	... N 125	M91055020	... P13	... G 126	↑	... P11	... F 110
M800G2SOL	... P29	... Q 126	↑	... P35	... T 102	↑	... P23	... M 112	M91651020	... P13	... G 119
M860A0FSW	... P35	... T 101	M90814004	... P19	... K 101	M91056004	... P17	... J 102	M91690015	... P15	... H 114
M90001043	... P33	... S 133	M90815002	... P9	... E 134	↑	... P21	... L 123	M91691015	... P15	... H 125
↑	... P35	... T 117	M90816004	... P19	... K 117	↑	... P27	... P 120	M91802006	... P9	... E 139
M90204060	... P5	... C 135	M90835050	... P35	... T 114	↑	... P33	... S 110	M91910080	... P3	... B 105
M90306041	... P33	... S 129	M90836050	... P9	... E 138	M91057004	... P29	... Q 122	M92004002	... P27	... P 130
M90316050	... P29	... Q 111	M90856004	... P3	... B 129	M91058020	... P15	... H 129	M92008045	... P31	... R 109
M90317050	... P19	... K 104	M90859004	... P7	... D 101	M91060021	... P19	... K 120	M93004021	... P19	... K 103
↑	... P35	... T 103	↑	... P15	... H 138	M91071004	... P3	... B 102	M93011021	... P29	... Q 112
M90337065	... P9	... E 103	↑	... P21	... L 127	↑	... P27	... P 117	M93016050	... P9	... E 105
M90406040	... P31	... R 103	M90862004	... P7	... D 111	↑	... P29	... Q 113	M93202047	... P15	... H 102
M90406064	... P9	... E 150	M90864004	... P29	... Q 115	↑	... P35	... T 105	M93220035	... P15	... H 101
M90409037	... P9	... E 112	M90865004	... P25	... N 105	M91084004	... P5	... C 146	M94001001	... P13	... G 108
↑	... P29	... Q 124	M90883080	... P3	... B 103	M91101085	... P27	... P 129	↑	... P19	... K 127
↑	... P33	... S 134	↑	... P9	... E 128	M91107045	... P17	... J 107	M94001017	... P13	... G 131
M90409041	... P35	... T 122	M90901002	... P5	... C 136	M91110045	... P17	... J 126	↑	... P23	... M 123
M90421050	... P13	... G 104	M90901045	... P25	... N 117	M91111015	... P17	... J 113	M94001037	... P21	... L 101
↑	... P21	... L 114	M90902011	... P15	... H 135	M91117002	... P17	... J 111	M94002017	... P3	... B 141
↑	... P23	... M 111	M90906003	... P3	... B 119	M91118002	... P11	... F 121	↑	... P19	... K 109
↑	... P25	... N 132	M90907010	... P17	... J 130	M91119002	... P9	... E 152	M94003017	... P19	... K 113
M90422050	... P19	... K 121	M90908003	... P3	... B 112	M91127015	... P13	... G 130	↑	... P23	... M 119
↑	... P25	... N 128	↑	... P15	... H 122	M91150003	... P5	... C 119	M94003021	... P27	... P 128
M90424053	... P25	... N 129	↑	... P25	... N 119	M91151010	... P17	... J 103	M94003099	... P29	... Q 106
M90434060	... P25	... N 134	M90909003	... P13	... G 121	M91182080	... P3	... B 108	M94005022	... P3	... B 138
M90500085	... P9	... E 131	M90910033	... P25	... N 112	M91200086	... P11	... F 104	M94006017	... P21	... L 115
M90504065	... P23	... M 101	M90913001	... P17	... J 127	M91201045	... P17	... J 118	M94006052	... P17	... J 108
M90505065	... P15	... H 119	M90920002	... P5	... C 101	M91202045	... P17	... J 134	M94007099	... P27	... P 119
↑	... P25	... N 123	M90921002	... P17	... J 133	M91212015	... P17	... J 138	M94008017	... P19	... K 114
M90511050	... P13	... G 110	M90922002	... P15	... H 113	M91276004	... P29	... Q 131	M94008045	... P21	... L 107
↑	... P17	... J 124	M90932015	... P25	... N 114	M91304080	... P3	... B 104	M94008070	... P23	... M 122
↑	... P19	... K 135	M90939002	... P5	... C 104	↑	... P19	... K 141	M94009021	... P13	... G 103
↑	... P21	... L 130	M90971004	... P13	... G 101	M91305080	... P25	... N 126	M94015021	... P23	... M 109
↑	... P23	... M 117	M90990002	... P3	... B 130	M91331004	... P5	... C 128	M94024017	... P17	... J 139
↑	... P35	... T 124	↑	... P7	... D 106	M91333004	... P3	... B 111	M94040021	... P13	... G 114
M90511065	... P3	... B 126	↑	... P9	... E 142	M91382045	... P23	... M 107	↑	... P19	... K 126
M90512050	... P11	... F 118	M91001075	... P19	... K 129	M91400010	... P7	... D 112	M95001017	... P21	... L 104
↑	... P19	... K 142	M91005022	... P25	... N 133	M91501022	... P17	... J 120	M95002017	... P3	... B 118
M90512065	... P25	... N 135	M91007045	... P23	... M 110	M91501085	... P5	... C 138	↑	... P11	... F 117
M90531060	... P23	... M 118	↑	... P25	... N 130	M91502045	... P17	... J 122	↑	... P17	... J 125
M90573080	... P27	... P 107	M91008035	... P27	... P 135	M91506001	... P15	... H 107	↑	... P23	... M 116
M90600085	... P15	... H 108	M91010089	... P33	... S 135	M91512022	... P17	... J 123	M95002020	... P5	... C 115
M90604065	... P11	... F 115	M91011004	... P3	... B 114	M91553015	... P15	... H 117	↑	... P9	... E 121
M90605010	... P3	... B 131	↑	... P5	... C 132	M91572045	... P15	... H 132	↑	... P35	... T 112
M90611060	... P21	... L 124	↑	... P17	... J 131	M91602001	... P9	... E 140	M95003017	... P35	... T 125
M90631050	... P3	... B 136	M91013004	... P23	... M 115	M91602020	... P11	... F 127	M95004017	... P19	... K 134
↑	... P15	... H 133	M91053020	... P5	... C 117	M91602046	... P5	... C 121	M95004020	... P5	... C 134
↑	... P25	... N 107	↑	... P9	... E 119	M91603003	... P15	... H 131	↑	... P9	... E 136

索引
INDEX-2

部品コード Parts No.	ページ Page	Fig No.	部品コード Parts No.	ページ Page	Fig No.	部品コード Parts No.	ページ Page	Fig No.	部品コード Parts No.	ページ Page	Fig No.
M95004020	... P13	... G 129	MB60A2620	... P33	... S 109	MF10A0709	... P5	... C 137	MH10A0456	... P9	... E 114
↑	... P15	... H 121	MB60A3957	... P31	... R 102	MF13A0135	... P27	... P 124	MH10A0530	... P9	... E 137
M95005017	... P21	... L 121	MB61A0458	... P7	... D 103	MF13A0191	... P5	... C 113	MH10A0553	... P5	... C 147
↑	... P33	... S 108	MB61A0470	... P3	... B 134	MF13A0192	... P5	... C 111	MH10A0571	... P25	... N 113
M95005021	... P19	... K 137	MB61A0477	... P21	... L 118	MF13A0350	... P5	... C 114	MH10A0572	... P9	... E 148
M95006021	... P19	... K 143	MB61A0762	... P37	... U 127	MF13A0452	... P11	... F 133	MH10A0584	... P5	... C 130
M95013021	... P19	... K 111	MB61A0797	... P35	... T 120	MF13A0456	... P11	... F 103	MH10A0602	... P29	... Q 103
M95014017	... P13	... G 109	MB61A1762	... P37	... U 128	MF13A0551	... P5	... C 102	MH10A0613	... P33	... S 107
M95037021	... P23	... M 104	MB61A3454	... P23	... M 105	MF13A0572	... P5	... C 112	MH10A0626	... P15	... H 112
M95052021	... P21	... L 131	MB61A5601	... P35	... T 121	MF13A0683	... P11	... F 134	MH10A0663	... P9	... E 129
M96001005	... P9	... E 125	MB61E0434	... P17	... J 902	MF13A0750	... P5	... C 106	MH10A0682	... P9	... E 111
↑	... P21	... L 111	MB61E1105	... P37	... U 126	MF13A0767	... P9	... E 126	MH10A0691	... P3	... B 109
M96001017	... P9	... E 102	MB61E4691	... P33	... S 901	MF13A0793	... P5	... C 108	MH10A0694	... P9	... E 108
↑	... P13	... G 111	MB62A0707	... P23	... M 114	MF13A0950	... P5	... C 103	MH10A0700	... P25	... N 109
M96001020	... P13	... G 118	MB62A0757	... P29	... Q 129	MF13A1456	... P11	... F 131	MH10A0722	... P9	... E 145
M96002001	... P21	... L 113	MB62A0921	... P21	... L 105	MF13A1683	... P11	... F 107	MH10A0729	... P25	... N 118
M96002017	... P3	... B 137	MB62A0957	... P23	... M 121	MF13A2191	... P5	... C 110	MH10A0742	... P3	... B 107
↑	... P25	... N 121	MB62A0975	... P23	... M 103	MF13A2767	... P11	... F 111	MH10A0750	... P9	... E 109
M96003070	... P21	... L 109	MB62A1434	... P23	... M 102	MF13A4750	... P11	... F 108	MH10A0760	... P15	... H 143
M96008017	... P3	... B 122	MB62A1957	... P23	... M 124	MF13A9750	... P11	... F 101	MH10A0763	... P15	... H 116
↑	... P11	... F 116	MB62A5454	... P21	... L 120	MF13E1767	... P11	... F 902	MH10A0767	... P19	... K 131
M96010052	... P25	... N 131	MB62A6477	... P23	... M 120	MF13E6456	... P11	... F 901	MH10A0770	... P35	... T 111
M96011017	... P15	... H 134	ME10A0571	... P19	... K 128	MF17A0565	... P33	... S 106	MH10A0830	... P3	... B 110
M97320099	... P35	... T 131	ME10A2780	... P29	... Q 108	MF17A1476	... P9	... E 104	MH10A0848	... P19	... K 125
M98016050	... P15	... H 136	ME10A7910	... P15	... H 126	MF17A2476	... P9	... E 107	MH10A0915	... P25	... N 110
M98087021	... P35	... T 115	ME18A2780	... P27	... P 116	MF20A0130	... P35	... T 119	MH10A0920	... P19	... K 105
MA16A0495	... P29	... Q 133	ME20A0120	... P11	... F 124	MF20A0229	... P11	... F 120	MH10A0980	... P25	... N 124
MA16A0621	... P17	... J 141	ME20A0339	... P29	... Q 107	MF23C0245	... P37	... U 115	MH10A0981	... P25	... N 116
MA20A0650	... P21	... L 117	ME20A0352	... P3	... B 116	MF25B0123	... P11	... F 123	MH10A1252	... P13	... G 120
MA20A0734	... P35	... T 116	ME20A0408	... P29	... Q 110	↑	... P33	... S 102	MH10A1352	... P13	... G 125
MA20A0781	... P21	... L 103	ME20A0915	... P17	... J 137	MF60A0700	... P15	... H 142	MH10A1407	... P13	... G 105
MA20A5571	... P17	... J 140	ME20E0477	... P17	... J 119	MF70A1180	... P5	... C 133	MH10A1417	... P25	... N 106
MA20A6571	... P29	... Q 135	ME25A0682	... P9	... E 151	MF80A0780	... P27	... P 106	MH10A1454	... P19	... K 133
MA20A8571	... P35	... T 126	ME40A0426	... P21	... L 122	MG30A0700	... P27	... P 134	MH10A1456	... P9	... E 113
MA21A0256	... P37	... U 111	ME40A0963	... P35	... T 123	MG30A0740	... P15	... H 124	MH10A1501	... P29	... Q 102
MA21A1256	... P37	... U 112	MF00A0391	... P17	... J 136	MG42A0181	... P9	... E 133	MH10A1508	... P35	... T 127
MA30A0571	... P33	... S 136	MF00A0608	... P33	... S 121	↑	... P37	... U 113	MH10A1530	... P25	... N 122
MA30A0964	... P29	... Q 130	MF00A1392	... P17	... J 110	MG43A0181	... P5	... C 145	MH10A1683	... P13	... G 128
MA35A0256	... P37	... U 109	MF00A1477	... P17	... J 121	MG43A1181	... P3	... B 113	MH10A1694	... P9	... E 106
MA35A1256	... P37	... U 110	MF00A1527	... P17	... J 101	MG44E0125	... P11	... F 122	MH10A1701	... P25	... N 136
MB02A0608	... P33	... S 120	MF00A1603	... P17	... J 128	MG75A0265	... P15	... H 106	MH10A1722	... P9	... E 120
MB02A1608	... P33	... S 119	MF00A2780	... P27	... P 112	MG75A1476	... P5	... C 127	MH10A1740	... P13	... G 123
MB10M0256	... P37	... U 106	MF00A8910	... P17	... J 112	MH10A0160	... P35	... T 104	MH10A1741	... P15	... H 141
MB25E0351	... P17	... J 901	MF01E0350	... P11	... F 903	MH10A0194	... P5	... C 116	MH10A1750	... P9	... E 115
MB60A0201	... P33	... S 128	MF01E0411	... P17	... J 117	MH10A0245	... P5	... C 148	MH10A1758	... P19	... K 136
MB60A0366	... P29	... Q 123	MF02A0834	... P17	... J 104	MH10A0252	... P13	... G 117	MH10A1848	... P13	... G 115
MB60A0420	... P33	... S 130	MF06A1620	... P33	... S 127	MH10A0267	... P15	... H 109	MH10A1850	... P13	... G 112
MB60A0429	... P19	... K 116	MF10A0149	... P33	... S 126	MH10A0283	... P15	... H 120	MH10A1920	... P19	... K 110
MB60A0719	... P31	... R 104	MF10A0181	... P5	... C 131	MH10A0348	... P5	... C 107	MH10A1956	... P15	... H 127
MB60A0778	... P19	... K 123	MF10A0187	... P5	... C 139	MH10A0364	... P9	... E 127	MH10A2181	... P5	... C 149
MB60A1368	... P31	... R 105	MF10A0325	... P9	... E 143	MH10A0416	... P9	... E 146	MH10A2476	... P13	... G 106
MB60A1429	... P19	... K 115	↑	... P15	... H 118	MH10A0417	... P5	... C 118	MH10A2508	... P35	... T 129
MB60A1620	... P33	... S 111	MF10A0553	... P5	... C 140	MH10A0418	... P35	... T 110	MH10A2708	... P13	... G 132
MB60A2352	... P29	... Q 125	MF10A0555	... P5	... C 124	MH10A0419	... P33	... S 103	MH10A2722	... P13	... G 107
MB60A2601	... P19	... K 119	MF10A0572	... P17	... J 116	MH10A0435	... P35	... T 109	MH10A2740	... P15	... H 140

索引
INDEX-3

部品コード Parts No.	ページ Page	Fig No.	部品コード Parts No.	ページ Page	Fig No.	部品コード Parts No.	ページ Page	Fig No.	部品コード Parts No.	ページ Page	Fig No.
MH10A2833	... P13	... G 127	MH20A0595	... P31	... R 101	MH27A0361	... P3	... B 120	MN52A1245	... P5	... C 142
MH10A2956	... P15	... H 139	MH20A0601	... P7	... D 102	MH27A0409	... P33	... S 131	↑	... P37	... U 116
MH10A2FUS	... P33	... S 105	MH20A0740	... P27	... P 115	MH27A0420	... P3	... B 121	MN60A0620	... P27	... P 131
MH10A3181	... P5	... C 150	MH20A0758	... P19	... K 140	MH27A0454	... P3	... B 125	MN70A1780	... P13	... G 122
MH10A3390	... P13	... G 116	MH20A0776	... P3	... B 142	MH27A0456	... P9	... E 123	↑	... P15	... H 123
MH10A3476	... P13	... G 113	MH20A0778	... P21	... L 102	MH27A0500	... P27	... P 123	MN70A2456	... P11	... F 109
MH10A3508	... P29	... Q 127	MH20A0833	... P13	... G 124	MH27A0516	... P27	... P 127	MP40A1740	... P27	... P 108
MH10A3FUS	... P33	... S 104	MH20A0849	... P3	... B 101	MH27A0523	... P11	... F 112	MS01A0155	... P9	... E 144
MH10A4508	... P29	... Q 128	MH20A0887	... P17	... J 114	MH27A0600	... P5	... C 120	MS01A1976	... P33	... S 114
MH10A4572	... P13	... G 133	MH20A0892	... P17	... J 115	MH27A0650	... P3	... B 123	MS02A0101	... P37	... U 101
MH10A4750	... P9	... E 901	MH20A0957	... P19	... K 102	MH27A0660	... P9	... E 130	MS02A0128	... P9	... E 135
MH10A5477	... P25	... N 111	MH20A1272	... P37	... U 129	MH27A0664	... P9	... E 132	↑	... P33	... S 101
MH10A5601	... P25	... N 120	MH20A1339	... P7	... D 109	MH27A0691	... P27	... P 126	MS02A0463	... P15	... H 902
MH10A5740	... P27	... P 105	MH20A1390	... P19	... K 138	MH27A0692	... P21	... L 108	MS02A0479	... P33	... S 122
MH10A5910	... P15	... H 115	MH20A1429	... P3	... B 135	MH27A0742	... P3	... B 139	MS02A0976	... P33	... S 117
MH10A6740	... P27	... P 104	MH20A1455	... P21	... L 112	MH27A0770	... P11	... F 119	MS02A1101	... P3	... B 132
MH10A6910	... P25	... N 115	MH20A1476	... P7	... D 115	MH27A0780	... P27	... P 118	MS02A1976	... P33	... S 116
MH10A7339	... P25	... N 102	MH20A1477	... P19	... K 107	MH27A0797	... P27	... P 139	MS02A2101	... P37	... U 102
MH10A7454	... P35	... T 113	MH20A1523	... P19	... K 139	MH27A0833	... P9	... E 147	MS02A2976	... P33	... S 115
MH10A7601	... P35	... T 106	MH20A1567	... P29	... Q 134	MH27A1339	... P3	... B 143	MS02B0257	... P21	... L 126
MH10A7740	... P27	... P 111	MH20A1601	... P7	... D 105	MH27A1450	... P11	... F 106	MS03A0181	... P37	... U 119
MH10A8601	... P35	... T 107	MH20A1758	... P19	... K 144	MH27A1454	... P9	... E 149	MS03A0256	... P37	... U 107
MH10A9601	... P29	... Q 114	MH20A1957	... P19	... K 112	MH27A1508	... P35	... T 130	MS03A0262	... P15	... H 110
MH10B1339	... P29	... Q 121	MH20A2339	... P7	... D 110	MH27A1650	... P3	... B 128	MS03A0703	... P15	... H 103
MH10B2339	... P29	... Q 120	MH20A2359	... P7	... D 107	MH27A1797	... P27	... P 140	MS03A1256	... P37	... U 108
MH10E0193	... P33	... S 118	MH20A2390	... P21	... L 106	MH27A1849	... P3	... B 140	MS03A1572	... P15	... H 105
MH10E0210	... P5	... C 903	MH20A2476	... P7	... D 116	MH27A2454	... P11	... F 113	MS03A2780	... P27	... P 101
MH10E0285	... P15	... H 901	MH20A2477	... P19	... K 108	MH27A2456	... P9	... E 903	MS05A0976	... P33	... S 113
MH10E0456	... P9	... E 902	MH20A2567	... P29	... Q 136	MH27A2601	... P29	... Q 119	MS05A1976	... P33	... S 112
MH10E1210	... P37	... U 118	MH20A2957	... P23	... M 125	MH27A2750	... P9	... E 122	MS06A0567	... P33	... S 137
MH10E2848	... P9	... E 101	MH20A3339	... P7	... D 113	MH27A2780	... P27	... P 102	MS07A0180	... P17	... J 132
MH10E3508	... P35	... T 902	MH20A3476	... P19	... K 122	MH27A3456	... P11	... F 114	MS07A0782	... P17	... J 105
MH10E5508	... P35	... T 901	MH20A3477	... P19	... K 124	MH27A4456	... P11	... F 904	MS07A0836	... P17	... J 106
MH20A0230	... P9	... E 117	MH20A3567	... P29	... Q 137	MH27A4750	... P11	... F 105	MS07A1603	... P17	... J 135
MH20A0257	... P7	... D 104	MH20A4339	... P7	... D 114	MH27A5750	... P11	... F 130	MS10A0180	... P37	... U 120
MH20A0266	... P23	... M 106	MH20A4567	... P29	... Q 138	MH27A6476	... P33	... S 132	MS10A0245	... P37	... U 117
MH20A0272	... P21	... L 129	MH20A5339	... P7	... D 117	MH27B1339	... P29	... Q 118	MS10A0451	... P11	... F 126
MH20A0273	... P21	... L 116	MH20A5567	... P29	... Q 139	MH27E0150	... P31	... R 901	MS10A0838	... P17	... J 129
MH20A0308	... P23	... M 113	MH20A6339	... P27	... P 901	MH27E0190	... P5	... C 901	MS10A1691	... P27	... P 137
MH20A0339	... P3	... B 124	MH20A7339	... P3	... B 117	MH27E0383	... P9	... E 905	MS10A1740	... P15	... H 130
MH20A0390	... P19	... K 130	MH20A8339	... P3	... B 127	MH27E0550	... P5	... C 904	MS10A1742	... P27	... P 138
MH20A0407	... P19	... K 118	MH20E0105	... P21	... L 901	MH27E0580	... P9	... E 904	MS10A1976	... P33	... S 124
MH20A0408	... P29	... Q 104	MH20E0270	... P25	... N 101	MH27E0599	... P29	... Q 901	MS10A2976	... P33	... S 125
MH20A0429	... P3	... B 115	MH20E0519	... P25	... N 104	MH27E2484	... P29	... Q 109	MS12A0257	... P21	... L 128
MH20A0450	... P11	... F 128	MH20E0688	... P27	... P 109	MH27E3484	... P29	... Q 116	MS13A0572	... P21	... L 125
MH20A0453	... P11	... F 129	MH20E1519	... P25	... N 127	MH27E3688	... P27	... P 110	MS14A0553	... P5	... C 125
MH20A0454	... P21	... L 110	MH20E1688	... P27	... P 113	MH27E5688	... P27	... P 136	MS14A0682	... P9	... E 118
MH20A0470	... P3	... B 133	MH20E2688	... P27	... P 114	MM11A0245	... P5	... C 123	MS14A1180	... P5	... C 126
MH20A0476	... P7	... D 108	MH20E3688	... P27	... P 122	MM11A0556	... P5	... C 141	MS14E0180	... P5	... C 902
MH20A0477	... P19	... K 106	MH20E4688	... P27	... P 132	MM11A0702	... P5	... C 122	MT60A0802	... P5	... C 143
MH20A0501	... P13	... G 102	MH20E5688	... P27	... P 133	MM11A1479	... P33	... S 123	MV30A0256	... P15	... H 111
MH20A0508	... P35	... T 128	MH27A0131	... P35	... T 118	MN10A0135	... P27	... P 121	↑	... P37	... U 104
MH20A0523	... P19	... K 132	MH27A0191	... P5	... C 109	MN10A1456	... P9	... E 124	MV30A1256	... P37	... U 105
MH20A0567	... P29	... Q 132	MH27A0225	... P27	... P 125	MN10A3245	... P37	... U 114	MV35A0106	... P37	... U 103
MH20A0572	... P23	... M 108	MH27A0228	... P15	... H 128	MN35A0628	... P15	... H 137			



お問い合わせは下記へどうぞ

F Aシステム事業本部 機器計画部 駆動機器グループ 〒100-8310 東京都千代田区丸の内 2-7-3 (東京ビル)
代表電話番号 (03)3218-6631 代表 F A X 番号 (03)3218-6823



FACTORY AUTOMATION SYSTEM GROUP

2-7-3, Marunouchi Chiyoda-ku Tokyo 100-8310, Japan

Fax : +81-3-3218-6821