

A 本体関係
 BODY & IT'S ACCESSORIES

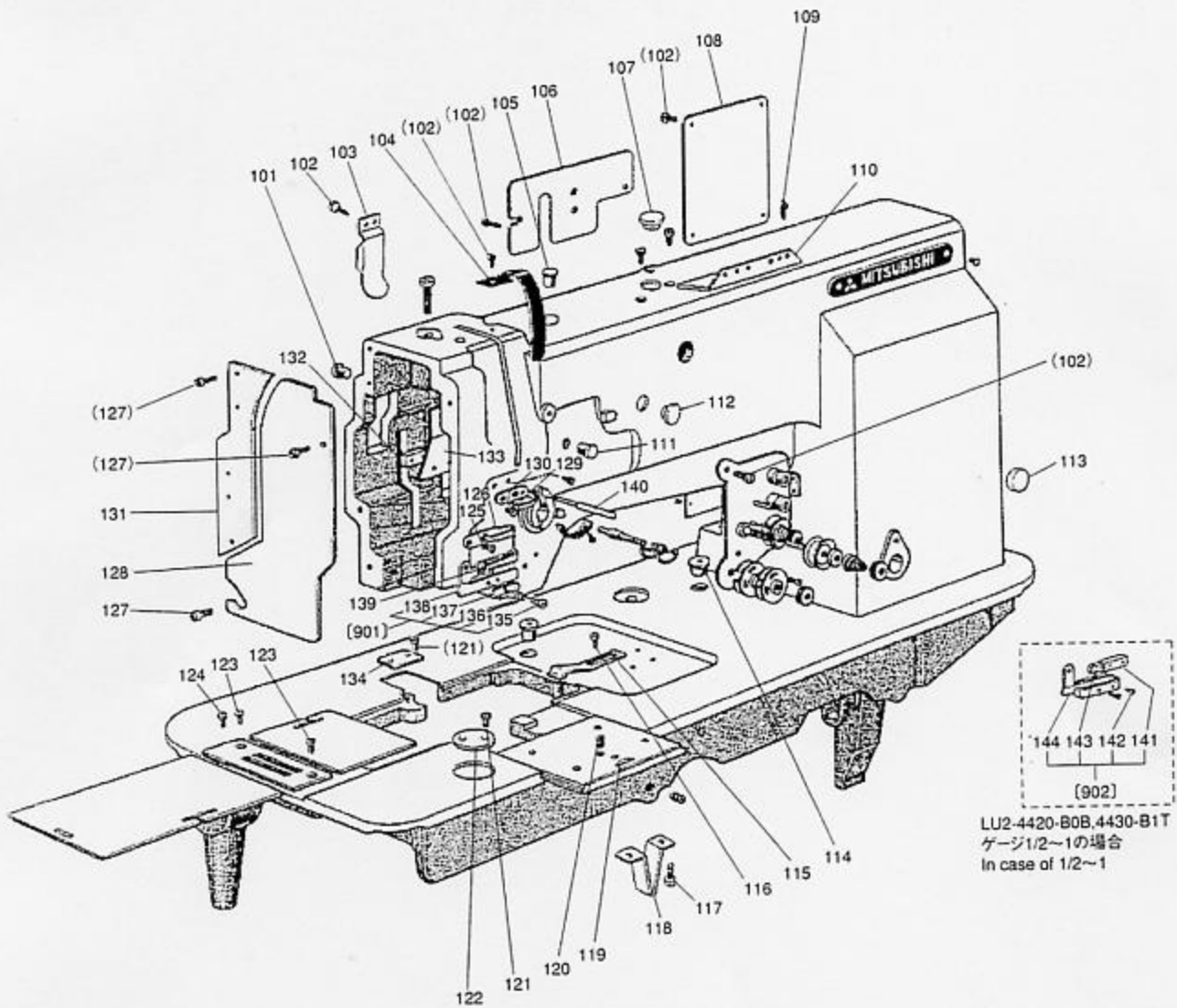

[A] 本体関係
BODY & IT'S ACCESSORIES

Fig. No.	部品コード Parts. No.	部品名	Description	使用個数 Amt. Req.					
				4400	4420	4410	4410-03	4430	4412-03
A101	M90883080	ゴムセン	RUBBER PLUG 8.8	2	2	2	2	2	2
A102	M91106004	ブラマイネジ	SCREW 11/64(40)X8	2	2	2	2	2	2
A103	MP60A0339	カバー	COVER	1	1	1	1	1	1
A104	MP60A0584	テンションカバー	TREAD TAKE-UP COVER	1	1	1	1	1	1
A105	M91304080	セン	RUBBER PLUG 13	1	1	1	1	1	1
A106	MP60A0880	ヨコフタ	ARM COVER	1	1	1	1	1	1
A107	MP60A0500	セン	RUBBER PLUG 23	1	1	1	1	1	1
A108	ML70A0237	ウラフタ	ARM COVER	1	1	1	1	1	-
A109	M91116002	ヒラネジ	SCREW 11/64(40)X8	2	2	2	2	2	2
A110	MN40A0180	イトアンナイ	THREAD GUIDE	1	1	1	1	1	1
A111	M91305080	セン	RUBBER PLUG 13	1	1	1	1	1	1
A112	M91910080	セン	RUBBER PLUG 19	1	1	1	1	1	1
A113	M91604080	セン	RUBBER PLUG 16	1	1	1	1	1	1
A114	MN10A4742	フタ	OIL CAP	2	2	2	2	2	2
A115	MP61A0192	イタハネ	SPRING	1	-	1	1	-	1
A116	M91128003	マルヒラネジ	SCREW 11/64(40)X6	2	2	2	2	2	2
A117	M91601003	マルヒラネジ	SCREW 1/4(24)X9	-	-	2	2	2	2
A118	MN50A0426	ササエ	SUPPORTER	-	-	1	1	1	1
A119	MN70A1472	スベリイタマエミタテ	SLIDE PLATE (FRONT)	-	1	-	-	1	-
A120	M91301001	トメネジ	SET SCREW 13/64(32)X4	-	1	-	-	1	-
A121	M90903010	サラネジ	SCREW 9/64(40)X6	-	-	2	2	4	2
A122	MN50A5742	フタ	COVER	-	-	-	-	1	-
A123	M91104011	マルサラネジ	SCREW 11/64(40)X8	2	1	2	2	1	2
A124	M90951003	マルヒラネジ	SCREW 9/64(36)X6.5	-	1	-	-	1	-
A125	M90904011	マルサラネジ	SCREW 9/64(40)X6.5	1	1	1	1	1	1
A126	MN10A1181	イトアンナイ	THREAD GUIDE	1	1	1	1	1	1
A127	M91109004	ザガネツキブラマイネジ	SCREW-PW 11/64(40)X9	13	13	13	13	13	13
A128	MP60A0830	メンイタ	FACE PLATE	1	1	1	1	1	1
A129	M91201011	マルサラネジ	SCREW 3/16(28)X11	2	2	2	2	2	2
A130	MN10A0181	イトアンナイ	THREAD GUIDE	1	1	1	1	1	1
A131	MP60A0601	ガイトトリツケイタ	ADAPTER	1	1	1	1	1	1
A132	MN10A0476	スベリサ	SPACER	1	1	1	1	1	1
A133	MN10A0131	アブラウケ	PLATE	1	1	1	1	1	1
A134	MP61A0742	フタ	COVER	-	-	1	1	-	1
A134	MP63A0742	フタ	COVER	-	-	-	-	1	-
A135	M90804016	マルヒラネジ タンツキ	SCREW 1/8(44)X3	1	1	1	1	1	1
A136	MP60A2572	ツルマキハネ	SPRING	1	1	1	1	1	1
A137	MP60A0202	イトサエ	PLATE	1	1	1	1	1	1
A138	MP60A0180	イトアンナイ	THREAD GUIDE	1	1	1	1	1	1
A139	M90920002	ヒラネジ	SCREW 9/64(40)X6.5	1	1	1	1	1	1
A140	M90514060	イトユルメピン	THREAD RELEASING PIN	1	1	-	-	-	-
A140	M90516060	イトユルメピン	THREAD RELEASING PIN	-	-	1	1	1	1
A141	MP00B0477	ストップパ	STOPPER	-	1	-	-	1	-
A142	M90604002	ヒラネジ	SCREW 3/32(56)X2.2	-	2	-	-	2	-
A143	MG23C1740	フェルト	FELT	-	1	-	-	1	-
A144	MP00B1180	イトアンナイ	THREAD GUIDE	-	1	-	-	1	-
A901	MP60E0180	イトアンナイクミタテ	THREAD GUIDE ASSY	1	-	1	1	-	1
A901	MP62E0180	イトアンナイクミタテ	THREAD GUIDE ASSY	-	1	-	-	1	-
A902	MN62E0180	イトアンナイクミタテ(1/2"~1"の場合)	THREAD GUIDE ASSY(IN CASE OF 1/2"~1")	-	1	-	-	1	-

Ⓑ 上糸調節器部分
 THREAD TENSION REGULATOR MECHANISM

Fig.901 LU2-4400-B0B

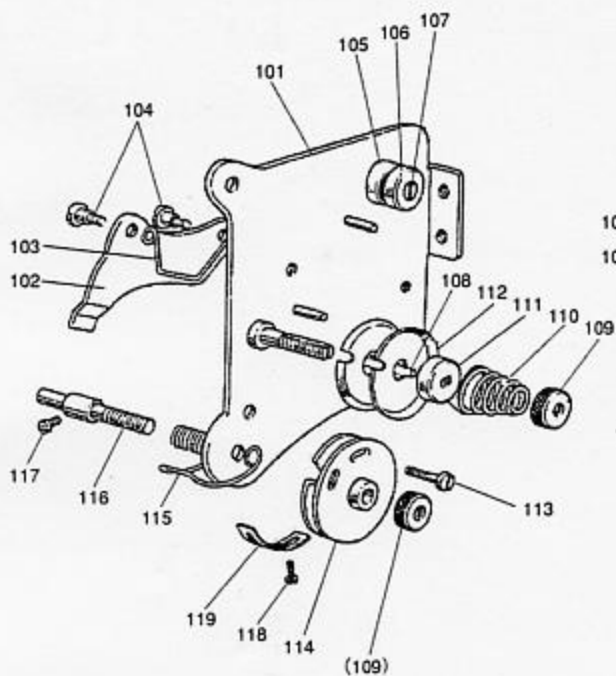

Fig.902 LU2-4420-B0B

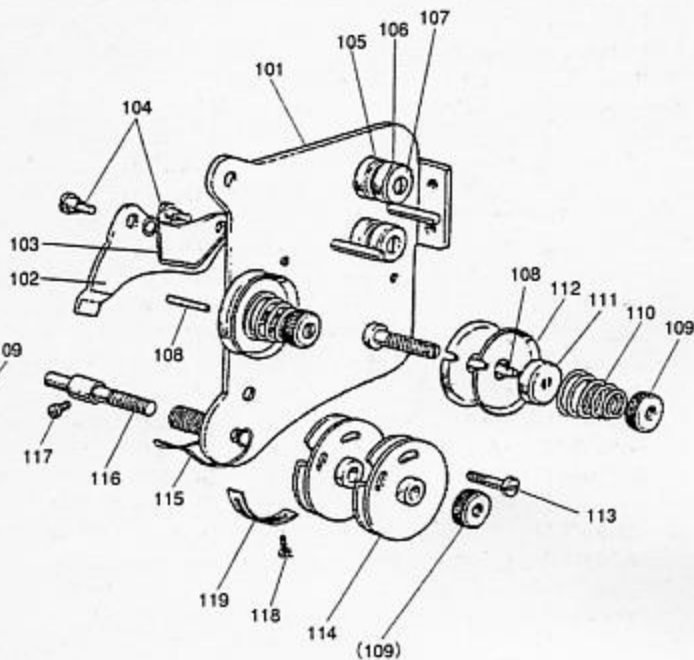

Fig.903 LU2-4410-B1T (-CS)
 LU2-4412-B1T-CS

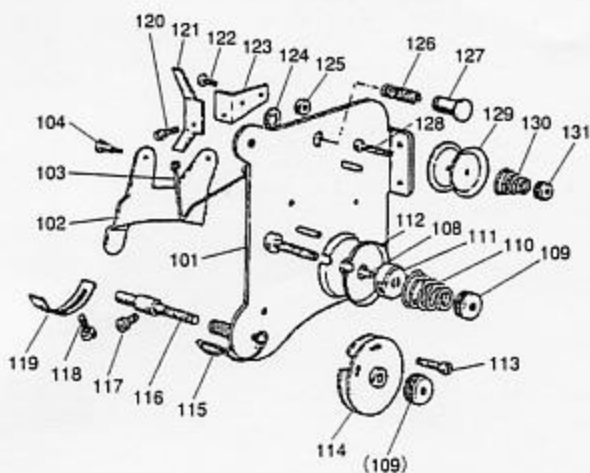
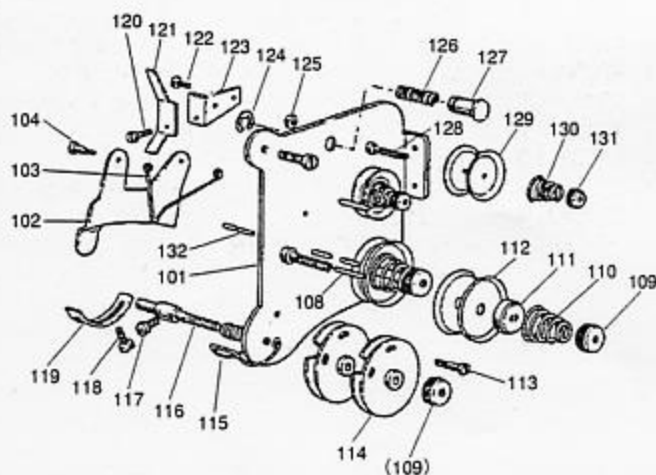

Fig.904 LU2-4430-B1T



[B] 上系調節器部分
 THREAD TENSION REGULATOR MECHANISM

Fig. No.	部品コード Parts No.	部品名	Description	使用個数 Amt. Req.					
				CS	CS	CS	CS	CS	CS
				4400	4420	4410	4410-CS	4430	4412-CS
B101	MP40E0601	トリツケイタクミタテ	MOUNTING PLATE ASSY	1	-	-	-	-	-
B101	MN10A0601	トリツケイタクミタテ	MOUNTING PLATE ASSY	-	1	-	-	-	-
B101	MP41E0601	トリツケイタクミタテ	MOUNTING PLATE ASSY	-	-	1	1	-	1
B101	MN50E0601	トリツケイタクミタテ	MOUNTING PLATE ASSY	-	-	-	-	1	-
B102	MN10A0220	イトユルメ	TENSION RELEASING PLATE	1	1	-	-	-	-
B102	MN50E0220	イトユルメカコウス	TENSION RELEASING PLATE	-	-	1	1	1	1
B103	MN10A0851	センサイバネ	REVERSE SPRING	1	1	1	1	1	1
B104	M90902015	ヒラネジ タンツキ	HINGED SCREW 9/64 (40) X6	2	2	2	2	2	2
B105	MN10A0155	アンナイダ イ	THREAD GUIDE BRACKET	1	2	-	-	-	-
B106	MN10A1555	チヨウシガラ	THREAD TENSION DISC	1	2	-	-	-	-
B107	M90902016	マルヒラネジ タンツキ	HINGED SCREW 9/64 (40) X18	1	2	-	-	-	-
B108	M90202060	ピン	THREAD RELEASING PIN 2X10.6	1	1	1	1	1	1
B109	M91603046	ツミナツト	THUMB NUT 1/4 (40)	2	3	2	2	3	2
B110	MF23C0245	エンスイバネ	TENSION SPRING	1	2	-	-	-	-
B110	MP41A0245	エンスイバネ	TENSION SPRING	-	-	1	1	2	1
B111	MN10A0556	チヨウシガラオサエ	THREAD TENSION PRESSER DISC	1	2	1	1	2	1
B112	MN10A0555	チヨウシガラ	THREAD TENSION DISC	2	4	2	2	4	2
B113	M90602003	マルヒラネジ	SCREW 3/32 (56) X6	1	-	1	1	-	1
B113	M90603003	マルヒラネジ	SCREW 3/32 (56) X12	-	1	-	-	1	-
B114	MN10E0175	イタクミタテ	THREAD CONTROL DISC ASSY	1	2	1	1	2	1
B115	MP60A1187	イトトリバネ	THREAD TAKE-UP SPRING	1	-	1	1	-	1
B115	MP62A0187	イトトリバネ	THREAD TAKE-UP SPRING	-	1	-	-	1	-
B116	MP10B0554	チヨウシジク	THREAD TENSION STUD	1	-	1	1	-	1
B116	MN10A0554	チヨウシジク	THREAD TENSION STUD	-	1	-	-	1	-
B117	M90910003	マルヒラネジ	SCREW 9/64 (40) X7	1	1	1	1	1	1
B118	M90920002	ヒラネジ	SCREW 9/64 (40) X6.5	1	1	1	1	1	1
B119	MN10A0477	ストツバ	STOPPER	1	1	1	1	1	1
B120	M90927015	ヒラネジ タンツキ	HINGED SCREW 9/64 (40) X5	-	-	1	1	1	1
B121	MN50A5950	レバ	LEVER	-	-	1	1	1	1
B122	M90906002	ヒラネジ	SCREW 9/64 (40) X4.5	-	-	1	1	1	1
B123	MN50A6601	トリツケイタ	MOUNTING PLATE	-	-	1	1	1	1
B124	M90505065	エカ タトメワ 5	RETAINING RING (E TYPE) 5	2	2	1	1	1	1
B125	M91101045	ナツト	NUT 11/64 (40)	-	-	1	1	1	1
B126	MN50A4572	ツルマキバネ	COIL SPRING	-	-	1	1	1	1
B127	MP41A1270	押しボタン	PUSH BUTTON	-	-	1	1	1	1
B128	MF10A1553	チヨウシホウ	THREAD TENSION STUD	-	-	1	1	2	1
B129	MN50A0555	チヨウシガラ	THREAD TENSION DISC	-	-	2	2	4	2
B130	MP61A0245	コイルバネ	SPRING	-	-	1	1	2	1
B131	M91609046	ツミナツト	THUMB NUT 1/4 (40)	-	-	1	1	2	1
B132	M90203060	ピン	THREAD RELEASING PIN 2X14.2	-	1	-	-	1	-
B901	MP60E0210	チヨウセツキクミタテ	THREAD TENSION REGULATOR ASSY	1	-	-	-	-	-
B902	MP62E0210	チヨウセツキクミタテ	THREAD TENSION REGULATOR ASSY	-	1	-	-	-	-
B903	MP61E0210	チヨウセツキクミタテ	THREAD TENSION REGULATOR ASSY	-	-	1	1	-	1
B904	MP63E0210	チヨウセツキクミタテ	THREAD TENSION REGULATOR ASSY	-	-	-	-	1	-

㊦ 上軸機構
UPPER SHAFT MECHANISM

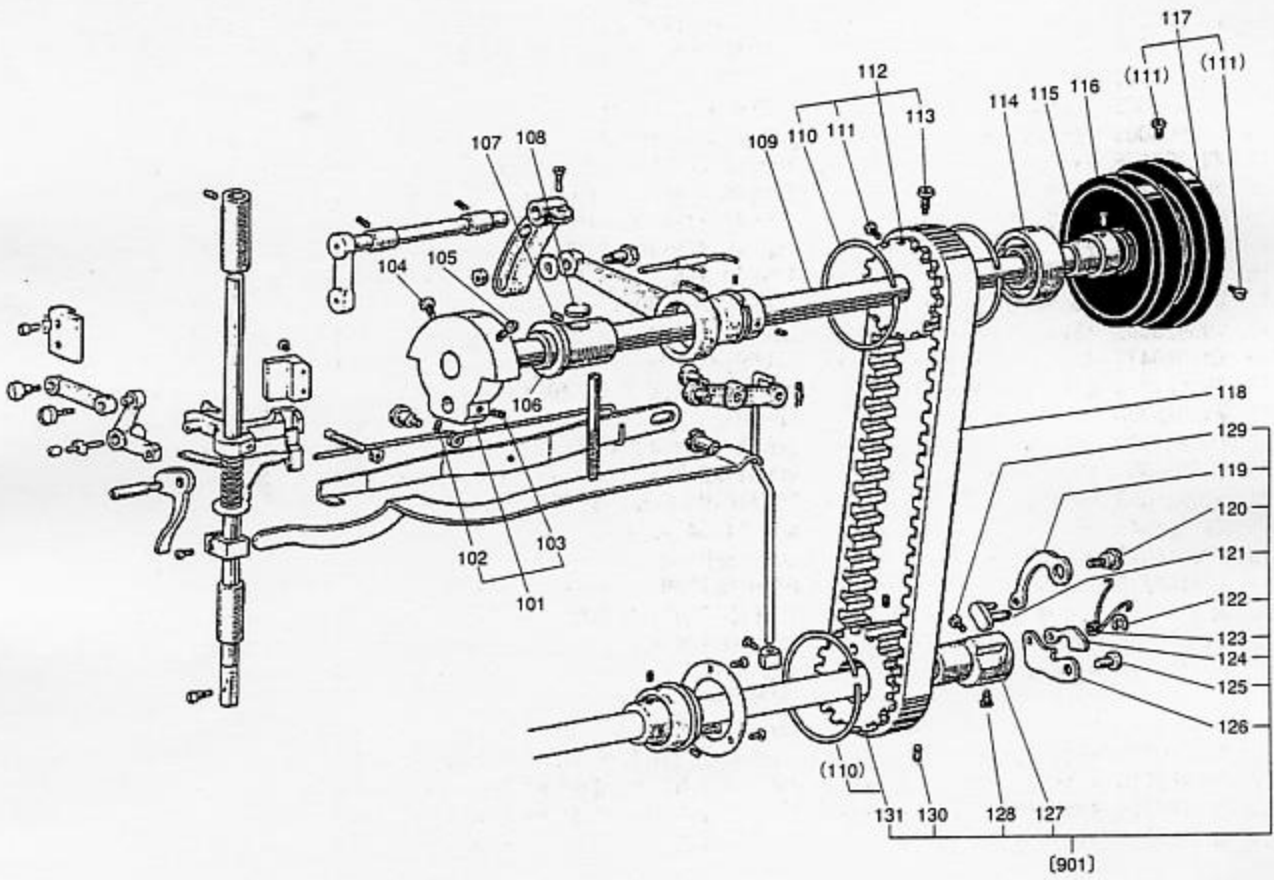

[C] 上軸機構
UPPER SHAFT MECHANISM

Fig. No.	部品コード Parts. No.	部品名	Description	使用個数 Amt. Req. CS					
				4400	4420	4410	4410	4430	4412-CS
C101	MP40A0383	クランクミタテ	CRANK	1	1	1	-	1	1
C101	MN42A0383	クランクミタテ	CRANK	-	-	-	1	-	-
C102	M91602001	トメネジ	SET SCREW 1/4 (40) X3.5	1	1	1	1	1	1
C103	M91606001	トメネジ	SET SCREW 1/4 (40) X7	1	1	1	1	1	1
C104	M91801002	ヒラネジ	SCREW 9/32 (28) X13	1	1	1	1	1	1
C105	M91802006	ヒラネジ ホウサキ	SCREW 9/32 (28) X14	1	1	1	1	1	1
C106	MN50A0232	ウツクメタルヒタリ	ARM SHAFT BUSHING (LEFT)	1	1	1	1	1	1
C107	M91654001	トメネジ	SET SCREW 1/4 (24) X13	1	1	1	1	1	1
C108	MN10A6740	フェルト	FELT	1	1	1	1	1	1
C109	MP60A0230	ウツク	ARM SHAFT	1	1	1	1	1	1
C110	MN10A1851	センサイクハネ	SPRING FLANGE	3	3	3	3	3	3
C111	M91502002	ヒラネジ	SCREW 15/64 (28) X12	3	3	1	1	1	1
C112	MP40A0767	ハカクハルトケルマクミタテ	BELT PULLEY (UPPER)	1	1	1	1	1	1
C113	M91501007	マルヒラネジ ホウサキ	SCREW 15/64 (28) X14.5	1	1	1	1	1	1
C114	MN10A1456	ジクウケ	BUSHING	1	1	-	-	-	-
C115	MN40A1750	ブツシュ	BUSHING FOR ARM SHAFT	1	1	-	-	-	-
C116	M91516002	ヒラネジ	SCREW 15/64 (28) X8.5	2	2	-	-	-	-
C117	MV11E0682	プーリークミタテ	PULLEY (ASSY)	1	1	-	-	-	-
C118	MP40A0523	ハカクハルト	COG BELT	1	1	1	1	1	1
C119	MP00B0871	イタハネ	SPRING PLATE	1	1	1	1	1	1
C120	M90605063	ヘンジンジク	ECCENTRIC HINGED PIN	1	1	1	1	1	1
C121	MP00B1910	リンク	LINK	1	1	1	1	1	1
C122	M90513065	エカクシメワ 2.5	RETAINING RING (E TYPE) 2.5	1	1	1	1	1	1
C123	MP00B0729	ヒネリバネ	TWIST SPRING	1	1	1	1	1	1
C124	MP00B0346	ツメ	CLUTCH PLATE	1	1	1	1	1	1
C125	M90617063	ダンツキジク	HINGED PIN	1	1	1	1	1	1
C126	MP00B0952	ツメ	PLATE FOR SAFETY CLUTCH	1	1	1	1	1	1
C127	MP00B1750	ブツシュ	BUSHING	1	1	1	1	1	1
C128	M91503007	マルヒラネジ ホウサキ	SCREW 15/64 (28) X10.5	1	1	1	1	1	1
C129	M91501003	ヒラネジ	SCREW 15/64 (28) X10	1	1	1	1	1	1
C130	M91503001	トメネジ	SET SCREW 15/64 (28) X4.5	2	2	2	2	2	2
C131	MP00B0768	ハカクハルトケルマ	COG BELT PULLEY (LOWER)	1	1	1	1	1	1
C901	MP00E0768	ハカクハルトケルマクミタテ	COG BELT PULLEY ASSY	1	1	1	1	1	1

㊦ 上部上下送り・押え機構

UPPER FEED LIFTING & PRESSER FOOT MECHANISM

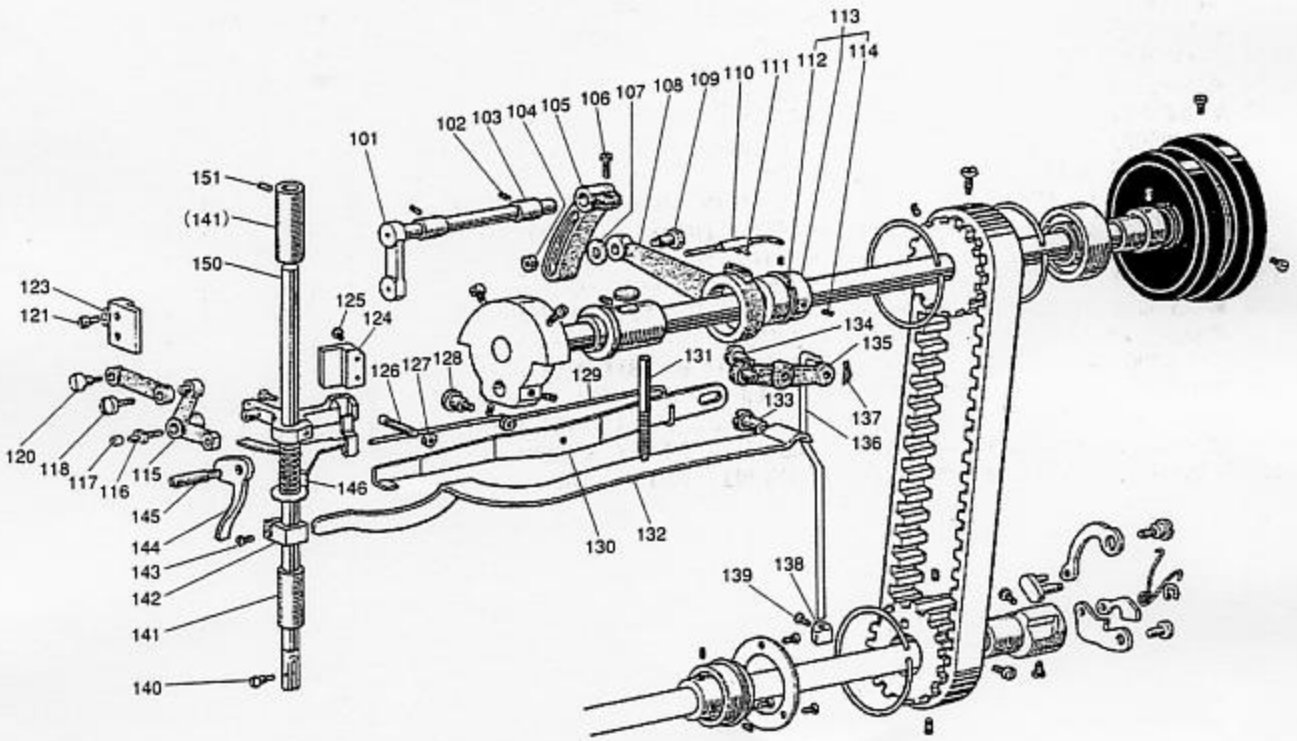

[D] 上部上下送り・押え機構
UPPER FEED LIFTING & PRESSER FOOT MECHANISM

Fig. No.	部品コード Parts No.	部品名	Description	使用個数 Amt. Req. CS					
				4400	4420	4410	4410- CS	4430	4412- CS
D101	MP40A0268	サトウシク	FEED LIFTING ROCK SHAFT	1	1	1	1	1	1
D102	M91653001	トメネジ	SET SCREW 1/4(24)X7	2	2	2	2	2	2
D103	MG10B0833	シヨウブシヨウケメタル	BUSHING	2	2	2	2	2	2
D104	M91572045	Uナット	NUT M6(0.75)	1	1	1	1	1	1
D105	MP00B0462	シヨウブシヨウケウテミキ	LIFTING ROCK SHAFT CRANK	1	1	1	1	1	1
D106	M91603003	マルヒラネジ	SCREW 1/4(24)X16	1	1	1	1	1	1
D107	M90601050	ミカキザガネ6	WASHER 6	1	1	1	1	1	1
D108	MF16A0384	レンセツカン	CRANK ROD	1	1	1	1	1	1
D109	M91551015	トクシユホルト	HINGED SCREW M6(0.75)X24	1	1	1	1	1	1
D110	MP40E5688	パイプヒモクミタテ	OIL PIPE ASSY	1	1	1	1	1	1
D111	MF60A0700	センサイクハネ	SPRING FOR FELT SUPPORTER	1	1	1	1	1	1
D112	M90325065	Cガタメワシクヨウ25	RETAINING RING (C TYPE) 25	1	1	1	1	1	1
D113	MP00B1760	ヘンシンリンクミタテ	ECCENTRIC FOR UPPER LIFTING	1	1	1	1	1	1
D114	M91606001	トメネジ	SET SCREW 1/4(40)X7	2	2	2	2	2	2
D115	MP41A0763	ベルクラック	BELL CRANK	1	1	1	1	1	1
D116	M90507063	ササエジク	ROLLER STUD	1	1	1	1	1	1
D117	MG10B0411	コロ	ROLLER	1	1	1	1	1	1
D118	M91151003	マルヒラネジ	SCREW 11/64(32)X6	1	1	1	1	1	1
D119	MP41A0956	レンセツカン	LINK FOR BELL CRANK	1	1	1	1	1	1
D120	M91681015	ヒラネジ タンツキ	HINGED SCREW 1/4(40)X12	1	1	1	1	1	1
D121	M91111003	マルヒラネジ	SCREW 11/64(40)X10	2	2	2	2	2	2
D122	MP41A0765	ベルクラックガイド	BELL CRANK GUIDE	1	1	1	1	1	1
D123	M90450050	ミカキザガネ4	WASHER 4	2	2	2	2	2	2
D124	MN50A0265	オサエホウダキガイド	GUIDE	1	1	1	1	1	1
D125	M91112002	ヒラネジ	SCREW 11/64(40)X12	2	2	2	2	2	2
D126	M91653002	ヒラネジ	SCREW 1/4(24)X19	1	1	1	1	1	1
D127	M91601045	ナット	NUT 1/4(24)	1	1	1	1	1	1
D128	M91601016	マルヒラネジ タンツキ	SCREW 1/4(24)X14	1	1	1	1	1	1
D129	MP40A0729	ヒネリハネ	SPRING	1	1	1	1	1	1
D130	MN40A0725	ヒザアケレバ	KNEE LIFTER LIFTING LEVER	1	1	1	1	1	1
D131	M91506033	ヒラネジ	SCREW 15/64(28)X79	1	1	1	1	1	1
D132	MN10A0258	イタハネ	PRESSER SPRING	1	1	1	1	1	1
D133	M91602016	マルヒラネジ タンツキ	HINGED SCREW 1/4(24)X29	1	1	1	1	1	1
D134	M91606016	マルヒラネジ タンツキ	HINGED SCREW 1/4(24)X30	1	1	1	1	1	1
D135	MN40E0724	ヒザアケウテクミタテ	KNEE LIFTER CRANK ASSY	1	1	1	1	1	1
D136	MP41A0511	ソウサホウ	KNEE LIFTER CONNECTING ROD	1	1	1	1	1	1
D137	M90105062	スナツブピン	SNAP PIN	1	1	1	1	1	1
D138	MN10A0352	カラー	COLLAR	1	1	1	1	1	1
D139	M91107002	ヒラネジ	SCREW 11/64(40)X5.5	1	1	1	1	1	1
D140	M90851015	ヒラネジ タンツキ	HINGED SCREW 1/8(44)X9	1	1	1	1	1	1
D141	MN10A0267	オサエホウメタル	BUSHING FOR PRESSER BAR	2	2	2	2	2	2
D142	ML75E0702	ハネウケ	SPRING SUPPORT BRACKET	1	1	1	1	1	1
D143	M90905002	ヒラネジ	SCREW 9/64(40)X8.5	1	1	1	1	1	1
D144	MN10A0252	オサエアケレバ	PRESSER BAR LIFTING LEVER	1	1	1	1	1	1
D145	M91113033	ヒラネジ	SCREWED PIN 11/64(40)X8.5	1	1	1	1	1	1
D146	MP00B1572	ツルマキハネ	COIL SPRING	1	1	-	-	-	-
D147	MN40A0221	イトユルメ	TENSION RELEASING PLATE	1	1	-	-	-	-
D148	MP40A0265	オサエホウダキクミタテ	PRESSER BAR HOLDING BRACKET	1	1	-	-	-	-
D148	MP41A0265	オサエホウダキクミタテ	PRESSER BAR HOLDING BRACKET	-	-	1	1	1	1
D149	M91113002	ヒラネジ	SCREW 11/64(40)X15	1	1	1	1	1	1
D150	MN10A0262	オサエホウ	PRESSER BAR	1	1	1	1	1	1
D151	M91654001	トメネジ	SET SCREW 1/4(24)X13	2	2	2	2	2	2

針棒・天秤機構

NEEDLE BAR & THREAD TAKE-UP LEVER MECHANISM

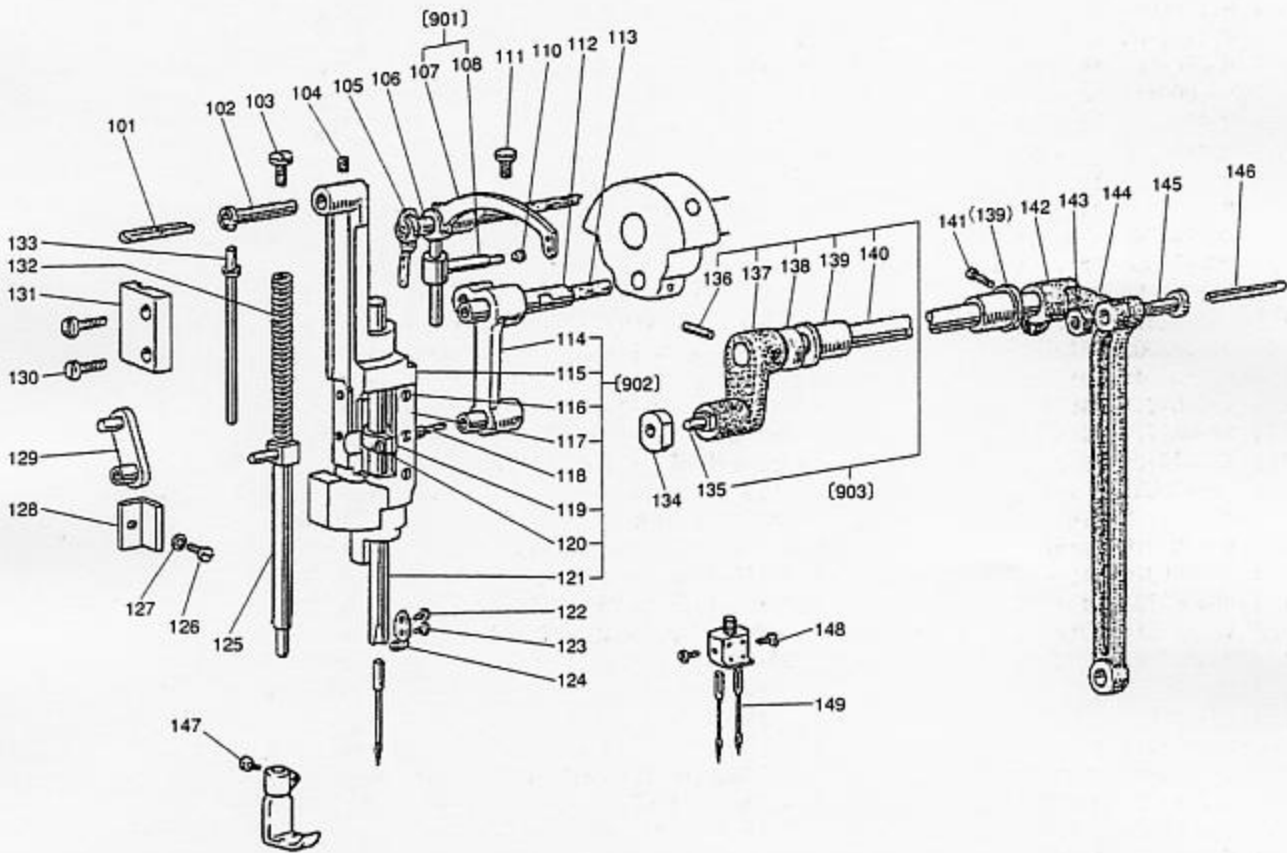

[E] 針棒・天秤機構
NEEDLE BAR & THREAD TAKE-UP LEVER MECHANISM

Fig. No.	部品コード Parts No.	部品名	Description	使用個数 Amt. Req.					
				4400	4420	4410	4410-3	4430	4412-03
E101	MF10E2148	ヒモ	OIL WICK 2.5X80	1	1	1	1	1	1
E102	MP40A0425	ササエジク	PIN FOR BRACKET SUPPORTER	1	1	1	1	1	1
E103	M92003002	ヒラネジ	SCREW 5/16(28)X10	1	1	1	1	1	1
E104	M91506001	トメネジ	SET SCREW 15/64(28)X8	1	1	1	1	1	1
E105	MF10E2148	ヒモ	OIL WICK 2.5X240	1	1	1	1	1	1
E106	MN10A0587	テンピンササエジク	PIN FOR THREAD TAKE-UP LEVER	1	1	1	1	1	1
E107	————	テンピン	THREAD TAKE-UP LEVER	-	-	-	1	-	1
E107	————	テンピン	THREAD TAKE-UP LEVER	1	1	1	-	1	-
E108	————	スベリカネ	SLIDE BLOCK	1	1	1	1	1	1
E109	MF10E3148	ヒモ	OIL WICK 3X25	1	1	1	1	1	1
E110	MN10A0500	セン	PLUG	1	1	1	1	1	1
E111	M91502002	ヒラネジ	SCREW 15/64(28)X12	1	1	1	1	1	1
E112	MN70A0387	ハリホウクランクジク	NEEDLE BAR CRANK PIN	1	1	1	1	1	1
E113	MP60A0148	ヒモ	OIL WICK 3X80	1	1	1	1	1	1
E114	MP60A1956	レンセツカン	NEEDLE BAR CONNECTING LINK	1	-	1	1	-	1
E114	MP00B0661	レンセツカン	NEEDLE BAR CONNECTING LINK	-	1	-	-	1	-
E115	MP60A1666	ハリホウササエ	NEEDLE BAR GUIDE BRACKET	1	-	1	1	-	1
E115	MP41A0666	ハリホウササエ	NEEDLE BAR GUIDE BRACKET	-	1	-	-	1	-
E116	M90604011	マルササネジ	SCREW 3/32(56)X4	6	6	6	6	6	6
E117	————	スペーサ	SPACER	2	2	2	2	2	2
E118	MN10A0740	フェルト	FELT	1	1	1	1	1	1
E119	MP60A0665	ハリホウウタキ	NEEDLE BAR HOLDER	1	-	1	1	-	1
E119	MP00B0665	ハリホウウタキ	NEEDLE BAR HOLDER	-	1	-	-	1	-
E120	M90949003	マルヒラネジ	SCREW 9/64(40)X8.5	1	-	1	1	-	1
E120	M90945003	マルヒラネジ	SCREW 9/64(40)X8.5	-	1	-	-	1	-
E121	MP60A0660	ハリホウ	NEEDLE BAR	1	-	1	1	-	1
E121	MP62A0660	ハリホウ	NEEDLE BAR	-	1	-	-	1	-
E122	M90602002	ヒラネジ	SCREW 3/32(56)X3	1	-	1	1	-	1
E123	M90801002	ヒラネジ	SCREW 1/8(44)X4.4	1	-	1	1	-	1
E124	MP46A0181	イトアンナイ	THREAD GUIDE	1	-	1	1	-	1
E125	MP00B0881	オサエホウ	VIBRATING PRESSER BAR	1	1	1	1	1	1
E126	M90107024	ミゾツキホルト	SCREW 11/64(40)X12	1	1	1	1	1	1
E127	M90401050	ザガネ	WASHER 4	1	1	1	1	1	1
E128	MN80A1154	アンナイカネ	NEEDLE BAR GUIDE	1	1	1	1	1	1
E129	MP00B0882	リンク	VIBRATING PRESSER BAR LINK	1	1	1	1	1	1
E130	M91113002	ヒラネジ	SCREW 11/64(40)X15	2	2	2	2	2	2
E131	MP00B0883	アンナイカネ	VIBRATING PRESSER BAR GUIDE	1	1	1	1	1	1
E132	MH19A0259	ツルマキバネ	COIL SPRING	1	1	1	1	1	1
E133	ML75A0884	アンナイホウ	VIBRATION PRESSER SPRING GUIDE	1	1	1	1	1	1
E134	MN25A0325	カクコマ	SQUARE BLOCK	1	1	1	1	1	1
E135	M90509060	ササエジク	CONNECTING STUD 5.5X9.5	1	1	1	1	1	1
E136	M90401061	テーパピン	TAPER PIN 4X23	1	1	1	1	1	1
E137	————	ハリホウウヨウトウウテヒタリ	NEEDLE BAR VIBRATING CRANK (LEFT)	1	1	1	1	1	1
E138	MN50A0352	カラー	COLLAR	1	1	1	1	1	1
E139	MN40A0669	ハリホウウヨウトウウテメタル	BUSHING FOR NEEDLE BAR ROCK SHAFT	2	2	2	2	2	2
E140	————	ハリホウウヨウトウウテ	NEEDLE BAR VIBRATING SHAFT	1	1	1	1	1	1
E141	M91603003	マルヒラネジ	SCREW 1/4(24)X16	1	1	1	1	1	1
E142	MN55A2672	ハリホウウヨウトウウテミキ	NEEDLE BAR ROCK SHAFT CRANK (RIGHT)	1	1	1	1	1	1
E143	M92002045	ナット	NUT 5/16(24)	1	1	1	1	1	1
E144	MN25A0671	レンセツカン	NEEDLE BAR ROCK SHAFT CRANK	1	1	1	1	1	1
E145	M92001015	ヒラネジ タンツキ	HINGED SCREW 5/16(24)X26.2	1	1	1	1	1	1
E146	MF10E2148	ヒモ	OIL WICK 2.5X85	1	1	1	1	1	1
E147	M91108002	ヒラネジ	SCREW 11/64(40)X7	1	1	1	1	1	1
E148	M90946003	マルヒラネジ	SCREW 9/64(40)X3.4	-	2	-	-	2	-
E149	MP20B0128	ミシンハリ DPX17-23	NEEDLE DPX17-23	1	2	1	1	2	1
E901	MP60E0582	テンピンスベリカネ組み立て	THREAD TAKE-UP LEVER ASSY	1	1	1	-	1	-
E901	MP41E0582	テンピンスベリカネ組み立て	THREAD TAKE-UP LEVER ASSY	-	-	-	1	-	1
E902	MP60E1666	ハリホウササエ組み立て	NEEDLE BAR GUIDE BRACKET ASSY	1	-	1	1	-	1
E902	MP62E1666	ハリホウササエ組み立て	NEEDLE BAR GUIDE BRACKET ASSY	-	1	-	-	1	-
E903	MP60E0668	ハリホウウヨウトウウテジク組み立て	NEEDLE BAR VIBRATING SHAFT ASSY	1	1	1	1	1	1

E 縫目加減機構
 STITCH REGULATOR MECHANISM

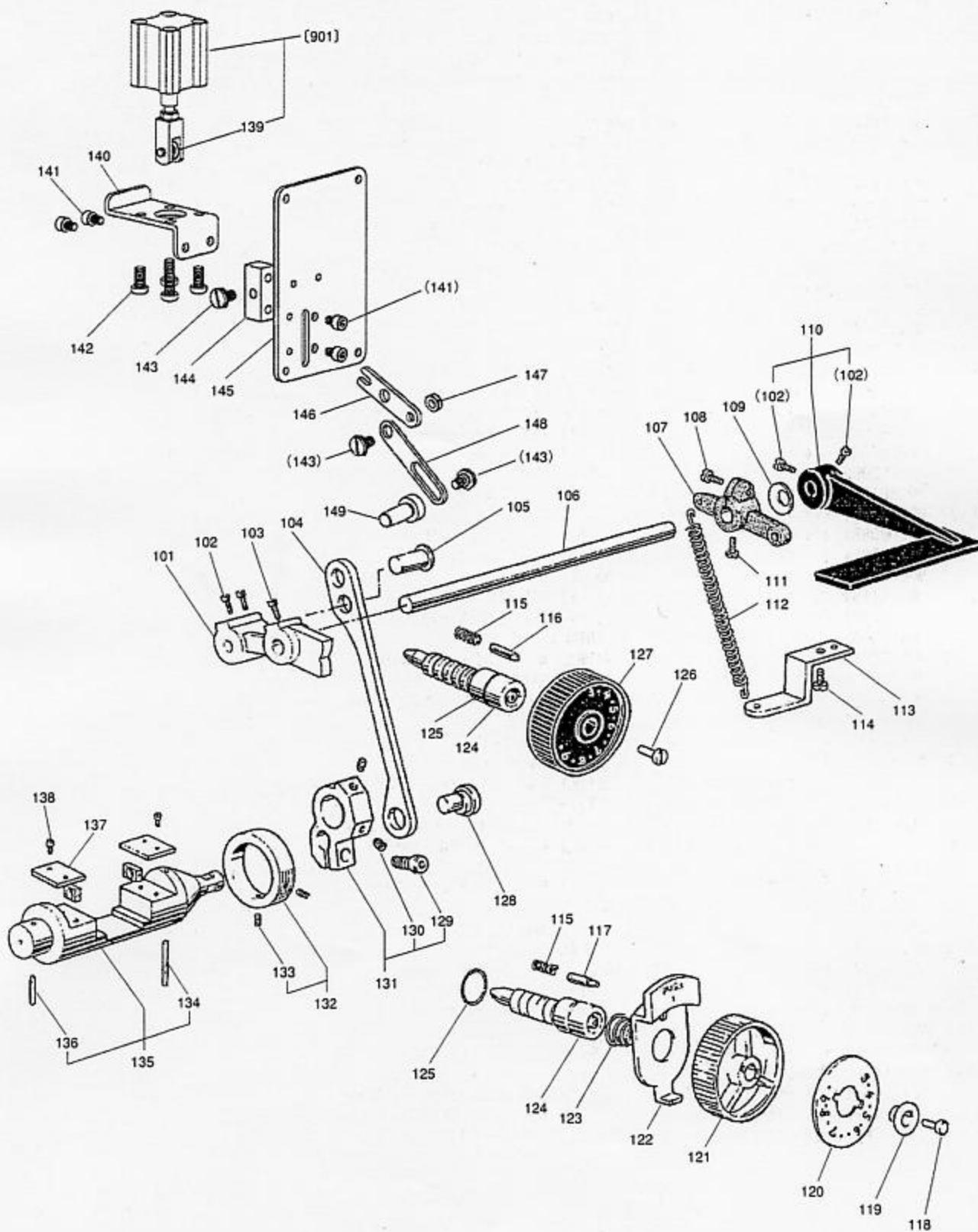

[F] 縫目加減機構
STITCH REGULATOR MECHANISM

Fig. No.	部品コード Parts.No.	部品名 Description	使用個数 Amt. Req.-CS					
			4400	4420	4410	4410-CS	4430	4412-CS
F101	MP47A0291	オクリチヨウセツカム	1	1	1	1	1	1
F102	M91516002	ヒラネジ	4	4	2	2	2	2
F103	M91505007	ヒラネジ ホウサキ	1	1	1	1	1	1
F104	MP60A0956	レンセツカン	1	1	1	1	1	1
F105	M90904060	ピン	1	1	1	1	1	-
F106	MN40A1320	カエシヌイジ クウエ	1	1	-	-	-	-
F106	MN40A0320	カエシヌイジ クウエ	-	-	1	1	1	1
F107	MP60A0228	ウデ	1	1	-	-	-	-
F107	MN50A3228	ウデ	-	-	1	1	1	1
F108	M91505002	ヒラネジ	1	1	1	1	1	1
F109	M95003053	ハネザカネ	1	1	-	-	-	-
F110	MN70A0632	ヌイメカゲンレバ	1	1	-	-	-	-
F110	MN72A0632	ヌイメカゲンレバ	-	-	1	1	1	1
F111	M91102002	ヒラネジ	1	1	1	1	1	1
F112	MN60A2572	ツルマキハネ	1	1	1	1	1	1
F113	MN40A0154	アンナイイタ	1	1	-	-	-	-
F114	M91110002	ヒラネジ	1	1	-	-	-	-
F115	MF10A2572	ツルマキハネ	1	1	1	1	1	1
F116	MF10A0852	ピン	1	1	-	-	-	-
F117	MF00A0852	ピン	-	-	1	1	1	1
F118	M91215002	ヒラネジ	-	-	1	1	1	1
F119	MF00A0257	オサエガネ	-	-	1	1	1	1
F120	MP61A0841	メモリイタ	-	-	1	1	1	-
F120	MP69A0841	メモリイタ	-	-	-	-	-	1
F121	MF01A0631	ダイヤル	-	-	1	1	1	1
F122	MF00A0950	レバ	-	-	1	1	1	1
F123	MF02A0245	エンスイハネ	-	-	1	1	1	1
F124	MF60A1640	オクリチヨウセツネジ	1	1	1	1	1	1
F125	M91000085	Oリング	1	1	1	1	1	1
F126	M91209002	ヒラネジ	1	1	-	-	-	-
F127	MP60A0631	ダイヤル	1	1	-	-	-	-
F128	MP60A0761	ヘンジンシク	1	1	1	1	1	1
F129	M95014021	ロツカクアナツキボルト	1	1	1	1	1	1
F130	M95008020	ロツカクアナツキトメネジ	2	2	2	2	2	2
F131	MP60E1635	ヌイメカゲンウデシタクミタテ	1	1	1	1	1	1
F132	MN45A0352	カラークミタテ	1	1	1	1	1	1
F133	M91506001	トメネジ	2	2	2	2	2	2
F134	MP40A1740	フェルト	1	1	1	1	1	1
F135	MN45A1321	カエシイフエルトクミタテ	1	1	1	1	1	1
F136	MP40A0740	フェルト	1	1	1	1	1	1
F137	MN45A0154	アンナイイタ	2	2	2	2	2	2
F138	M91106004	ブラマイネジ	4	4	4	4	4	4
F139	M90519050	ナイロンワッシャ	-	-	-	-	-	2
F140	MP69A0601	トリツケイタ	-	-	-	-	-	1
F141	M91511056	セフティワッシャ	-	-	-	-	-	4
F142	M96062021	ボルト	-	-	-	-	-	4
F143	M91503031	ボルト	-	-	-	-	-	3
F144	MP69A0603	トリツケイタ	-	-	-	-	-	1
F145	MP69A0237	ウラフタ	-	-	-	-	-	1
F146	MP69A0910	クトウリンク	-	-	-	-	-	1
F147	M91502045	ナット	-	-	-	-	-	1
F148	MP69A1910	リンク	-	-	-	-	-	1
F149	M90910060	ピン	-	-	-	-	-	1
F901	MP69A0434	エアシリンダクミタテ	-	-	-	-	-	1

㊄ 下軸・送り機構

LOWER SHAFT & FEED ROCKING MOTION MECHANISM

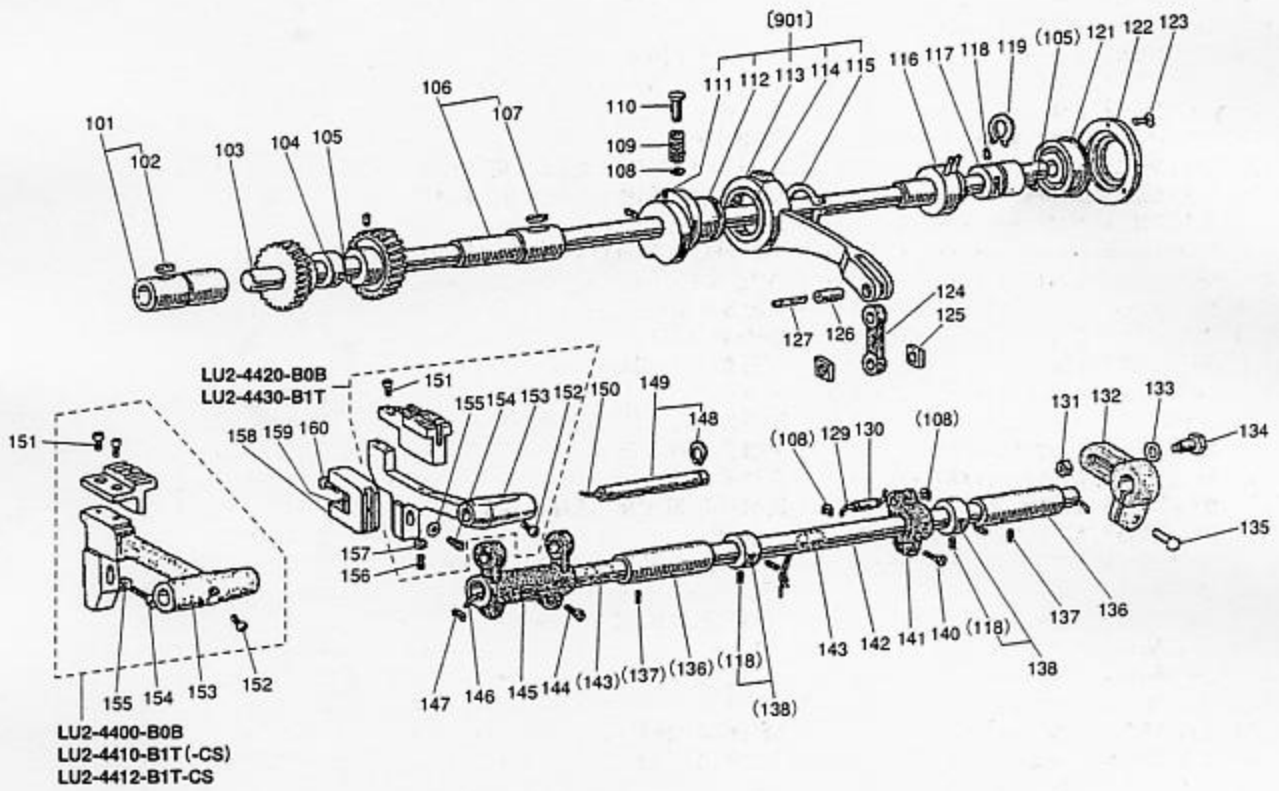

[G] 下軸・送り機構

LOWER SHAFT & FEED ROCKING MOTION MECHANISM

Fig. No.	部品コード Parts. No.	部品名	Description	使用個数 Amt. Req.					
				4400	4420	4410	4410-G	4430	4412-GS
G101	MN10A0451	シタジ'クメタルヒタ'リクミタテ	BUSHING FOR LOWER SHAFT (LEFT)	1	1	1	1	1	1
G102	MN70E1148	ヒモ	OIL WICK 2X45	1	1	1	1	1	1
G103	MP40A0450	シタジ'ク	LOWER SHAFT	1	1	1	1	1	1
G104	MN10A0292	ヘンシンリン	FEED LIFTING ECCENTRIC CAM	1	1	1	-	1	1
G104	MP40A0760	ヘンシンリン	FEED LIFTING ECCENTRIC CAM	-	-	-	1	-	-
G105	M91603001	トメネジ'ホ'ウサキ	SET SCREW 1/4(40)X5	2	2	2	2	2	2
G106	MP40A0452	シタジ'クメタルミキ'クミタテ	BUSHING FOR LOWER SHAFT (RIGHT)	1	1	1	1	1	1
G107	MN70E1148	ヒモ	OIL WICK 2X85	1	1	1	1	1	1
G108	M90505065	Eカ'タ'トメ'5	RETAINING RING (E TYPE) 5	3	3	3	3	3	3
G109	MP41A0572	ツルマキハ'ネ	COIL SPRING	1	1	1	1	1	1
G110	MP41A0270	オシホ'タン	PUSH BUTTON	1	1	1	1	1	1
G111	M91516001	トメネジ'	SET SCREW 15/64(28)X13.5	2	2	2	2	2	2
G112	MP40A0492	スイヘイオクリカム	FEED CAM	1	1	1	1	1	1
G113	MN40A0293	オクリロツト'	FEED CONNECTING ROD	1	1	1	1	1	1
G114	MN40A0456	ジ'クウケ	BUSHING	1	1	1	1	1	1
G115	M90526065	C'カ'タ'トメ'ジ'クヨウ'26	RETAINING RING (C TYPE) 26	1	1	1	1	1	1
G116	MP40E0453	シタジ'クメタルナカクミタテ	BUSHING FOR LOWER SHAFT (MIDDLE) ASSY	1	1	1	1	1	1
G117	MP47A2750	ブ'ツシュ	BUSH	1	1	1	1	1	1
G118	M91602001	トメネジ'	SET SCREW 1/4(40)X4	3	3	3	3	3	3
G119	M90317065	C'カ'タ'トメ'ジ'クヨウ'17	RETAINING RING (C TYPE) 17	1	1	1	1	1	1
G121	MN10A2456	ジ'クウケ	BUSHING	1	1	1	1	1	1
G122	MN10A0771	オサエイタ'	BEARING HOLDING PLATE	1	1	1	1	1	1
G123	M90902011	マルサラネジ'	SCREW 9/64(40)X7	3	3	3	3	3	3
G124	MN40A1956	レンセツカン	LINK	1	1	1	1	1	1
G125	MN40A0325	カクコマ	SQUARE BLOCK	2	2	2	2	2	2
G126	MN40A0454	ジ'ク	PIN FOR FEED CONNECTING ROD	1	1	1	1	1	1
G127	MP40A0148	ヒモ	OIL WICK 3X26	1	1	1	1	1	1
G129	MP40A0148	ヒモ	OIL WICK 3X55	1	1	1	1	1	1
G130	MN40A1454	ジ'ク	PIN	1	1	1	1	1	1
G131	M91572045	U'ナツト'6X0.75	NUT M6X0.75	1	1	1	1	1	1
G132	MP41A0275	オクリウテ'	FEED CONNECTING CRANK (RIGHT)	1	1	1	1	1	1
G133	M90602050	ザ'ガ'ネ	WASHER 6	1	1	1	1	1	1
G134	M91552015	トクシホ'ルト	SCREW	1	1	1	1	1	1
G135	M91603003	マルヒラネジ'	SCREW 1/4(24)X16	1	1	1	1	1	1
G136	MF70A0286	オクリジ'クメタル	BUSHING FOR FEED ROCK SHAFT	2	2	2	2	2	2
G137	M91654001	トメネジ'	SET SCREW 1/4(24)X13	2	2	2	2	2	2
G138	MF80A0352	カラ'クミタテ	COLLAR	2	2	2	2	2	2
G140	M91603003	マルヒラネジ'	SCREW 1/4(24)X16	1	1	1	1	1	1
G141	MN40A0273	オクリウテ'ナカ	FEED ROCK SHAFT CRANK (MIDDLE)	1	1	1	1	1	1
G142	MN40A0491	スイヘイオクリジ'ク	FEED ROCK SHAFT	1	1	1	1	1	1
G143	MP40A2740	フェルト	FELT	2	2	2	2	2	2
G144	M91204003	マルヒラネジ'	SCREW 3/16(28)X12	2	2	2	2	2	2
G145	MN40A0278	スイヘイオクリウテ'ヒタ'リ	FEED ROCK SHAFT CRANK (LEFT)	1	1	-	-	-	-
G145	MN50A0278	スイヘイオクリウテ'ヒタ'リ	FEED ROCK SHAFT CRANK (LEFT)	-	-	1	1	1	1
G146	MF10E0148	ヒモ	OIL WICK 2.5X430	1	1	1	1	1	1
G147	MF80A0780	ホルダ'	HOLDER FOR OIL WICK	1	1	1	1	1	1
G148	M90335065	C'カ'タ'トメ'ジ'クヨウ'7	RETAINING RING-C TYPE 7	1	1	1	1	1	1
G149	MN70E0454	ジ'ククミタテ	SHAFT	1	1	1	1	1	1
G150	MF10E2148	ヒモ	OIL WICK 2.5X150	1	1	1	1	1	1
G151	M90803020	ロツカクアナツキネ'ルト	BOLT 1/8(40)X7	2	2	2	2	2	2
G152	M95004021	ロツカクアナツキトメネジ'	SOCKET SET SCREW M5X5	1	1	1	1	1	1
G153	MP47A0281	オクリタ'イ	FEED BAR	1	-	1	-	1	-
G153	MN40A3281	オクリタ'イ	FEED BAR	-	1	-	-	-	-
G153	MP48A0281	オクリタ'イ	FEED BAR	-	-	-	-	1	-
G154	M91516022	ホ'ルト	BOLT 15/64(28)X10	1	1	1	1	1	1
G155	M90631050	ミガ'キザ'ガ'ネ	WASHER 6	1	1	1	1	1	1
G156	M93006020	ロツカクアナツキトメネジ'	SCREW M3X14	-	1	-	-	1	-
G157	M90879045	トメナツト	NUT M3	-	1	-	-	1	-
G158	MN40A0744	フタマタ	FEED BAR CONNECTING FORK	1	1	1	1	1	1
G159	MP42A0740	フェルト	FELT	1	1	1	1	1	1
G160	M90804003	マルヒラネジ'	SCREW 1/8(44)X4	1	1	1	1	1	1
G901	MP60E0305	オクリロツト'クミタテ	FEED REGULATOR ASSY	1	1	1	1	1	1

☐ カマ台機構
HOOK SADDLE MECHANISM

LU2-4420-B0B
LU2-4430-B1T

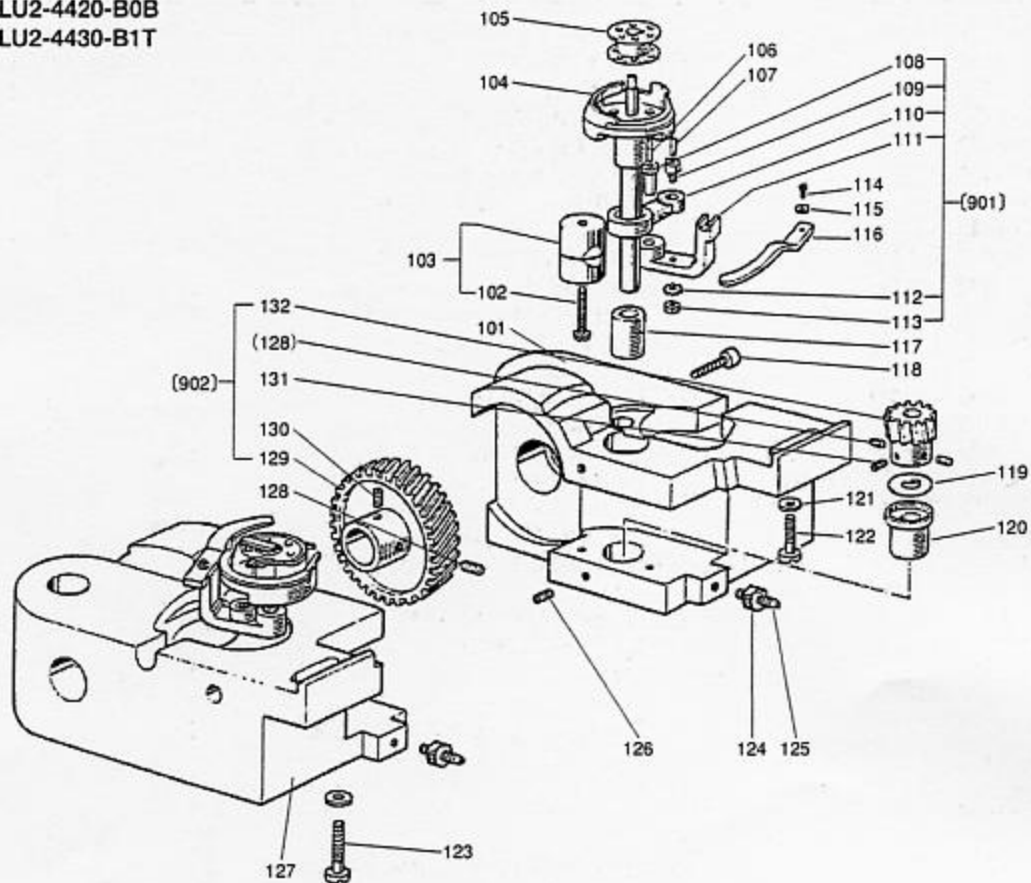

LU2-4400-B0B
LU2-4410-B1T(-CS)
LU2-4412-B1T-CS

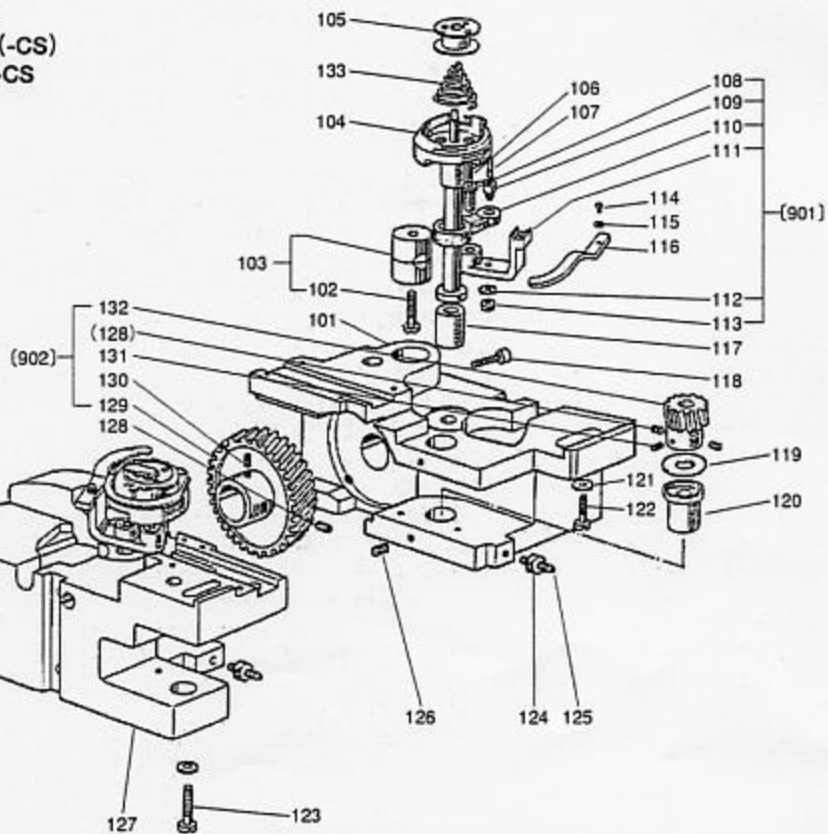

[H] カマ台機構
HOOK SADDLE MECHANISM

Fig. No.	部品コード Parts. No.	部 品 名	Description	使用個数 Amt. Req.					
				4400	4420	4410	4410	4430	4412-03
H101	MP40A0345	カマダ イミキ	HOOK SADDLE (RIGHT)	1	1	-	-	-	-
H101	MN60A1345	カマダ イミキ	HOOK SADDLE (RIGHT)	-	-	1	1	1	1
H102	M91509002	ヒラネジ	SCREW 15/64 (28) X22	1	2	1	1	2	1
H103	MN70A2750	ブ ッシユクミタテ	BUSHING	1	2	1	1	2	1
H104	MP00A0120	カマクミタテ	HOOK ASSY	1	2	-	-	-	-
H104	MP61A2120	カマクミタテ	HOOK ASSY	-	-	1	1	2	1
H105	MN12B0123	ホ ビン	BOBBIN	1	2	-	-	-	-
H105	MP60A0123	ホ ビン	BOBBIN	-	-	1	1	2	1
H106	MF10E2148	ヒモ	OIL WICK 2.5X24	-	-	1	1	2	1
H107	MF10E2148	ヒモ	OIL WICK 2.5X15	2	4	1	1	2	1
H108	MN10A0302	オープ ナササエジ ク	OPENER HOLDER PIN	1	2	1	1	2	1
H109	M91260030	トクシユネジ	SCREW 3/16 (32) X7.8	1	2	1	1	2	1
H110	MP40A0340	レンセツカン	LINK FOR HOOK SHAFT	1	2	1	1	2	1
H111	MN52A0301	オープ ナーササエ	OPENER HOLDER	1	2	1	1	2	1
H112	M90102053	ハ ネザ カ ネ 5	SPRING WASHER 5	1	2	1	1	2	1
H113	M91252045	ナツト	NUT 3/16 (32)	1	2	1	1	2	1
H114	M90910003	マルヒラネジ	SCREW 9/64 (40) X7	1	2	1	1	2	1
H115	M90401050	ザ カ ネ	WASHER 4	1	2	1	1	2	1
H116	MN52A0300	オープ ナー	OPENER	1	2	1	1	2	1
H117	MN12B0342	カマジ クメタルウエ	BUSHING FOR HOOK SHAFT (UPPER)	1	2	1	1	2	1
H118	M91201020	ロツカクアナツキトメネジ	SCREW 3/16 (28) X14.5	1	2	1	1	2	1
H119	M91001050	ザ カ ネ	WASHER 10	1	2	1	1	2	1
H120	MN10A0343	カマジ クメタルシタ	BUSHING FOR HOOK SHAFT (LOWER)	1	2	1	1	2	1
H121	M90601050	ミカ キザ カ ネ 6	WASHER 6	1	2	1	1	2	1
H122	M91651002	ヒラネジ	SCREW 1/4 (24) X23	1	1	1	1	1	1
H123	M91658002	ヒラネジ	SCREW 1/4 (24) X30	-	1	-	-	1	-
H124	M91201045	ナツト	NUT 3/16 (28)	1	2	1	1	2	1
H125	M91205030	トクシユネジ	SCREW 3/16 (28) X11.5	1	2	1	1	2	1
H126	M91503001	トメネジ	SET SCREW 15/64 (28) X4.5	2	4	2	2	4	2
H127	MP40A0344	カマダ イヒタリ	HOOK SADDLE (LEFT)	-	1	-	-	-	-
H127	MN60A1344	カマダ イヒタリ	HOOK SADDLE (LEFT)	-	-	-	-	1	-
H128	M91602001	トメネジ	SET SCREW 1/4 (40) X4	3	6	3	3	6	3
H129	MP41E0642	ネジ ハウ ルマ	GEAR (LARGE)	1	2	1	1	2	1
H130	M91655001	トメネジ	SET SCREW 1/4 (40) X6.5	1	2	1	1	2	1
H131	M91603001	トメネジ ホ ウサキ	SCREW 1/4 (40) X5	1	2	1	1	2	1
H132	MP00B0643	ネジ ハウ ルマ	GEAR (SMALL)	1	2	1	1	2	1
H133	MN52A2245	エンスイハ ネ	SPRING	-	-	1	1	2	1
H901	MN10E0301	オープ ナーササエクミ	OPENER HOLDER ASSY	1	2	1	1	2	1
H902	MP41E0644	ネジ ハウ ルマクミタテ	GEAR ASSY	1	2	1	1	2	1

J 糸切り機構 (I)
 KNIFE MECHANISM (I)

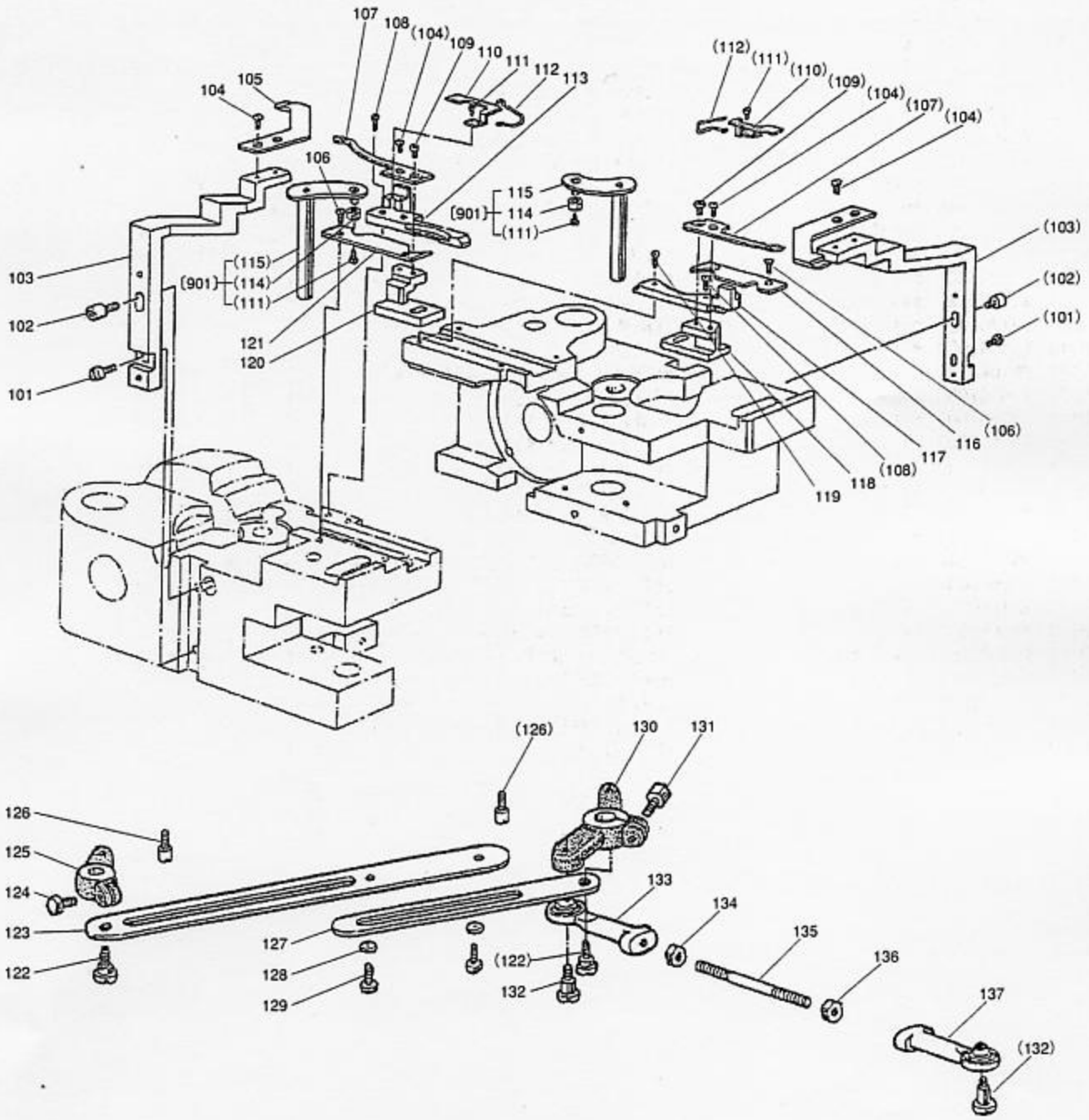

[J] 系切り機構 (I)
KNIFE MECHANISM (I)

Fig. No.	部品コード Parts. No.	部品名	Description	使用個数 Amt. Req. CS					
				4400	4420	4410	4410	4430	4412-CS
J101	M90911030	トクシユネジ	SCREW 9/64 (40) X8	-	-	1	1	2	1
J102	M91106022	ロツカクアナツキホルト	BOLT 11/64 (40) X12	-	-	1	1	2	1
J103	MN50A0839	メストリツケタイ	MOVED KNIFE HOLDER	-	-	1	1	2	1
J104	M91102010	サラネジ	SCREW 11/64 (40) X5	-	-	3	3	6	3
J105	MP41A0838	コテイメス	FIXED KNIFE	-	-	1	1	2	-
J105	MP69A0838	コテイメス	FIXED KNIFE	-	-	-	-	-	1
J106	M90903010	サラネジ	SCREW 9/64 (40) X6	-	-	2	2	4	2
J107	MP41B0838	イトウメス	MOVED KNIFE	-	-	1	1	2	1
J108	M90801010	サラネジ	SCREW 1/8 (44) X10	-	-	1	1	2	1
J109	M90944002	ヒラネジ	SCREW 9/64 (40) X4.5	-	-	1	1	1	1
J110	MN50A0192	イタバネ	SPRING PLATE	-	-	1	1	2	1
J111	M90605002	ヒラネジ	SCREW 3/32 (56) X3.8	-	-	3	3	6	3
J112	MN50A0507	センサイクハネ	SPRING	-	-	1	1	2	1
J113	MN60E1154	アンナイガネ	GUIDE	-	-	-	-	1	-
J114	MN60A0411	コロ	ROLLER	-	-	1	1	2	1
J115	MN60A1950	レバ	LEVER	-	-	1	1	2	1
J116	MN60A2742	フタ	COVER	-	-	1	1	1	1
J117	MN60E0154	アンナイガネ	GUIDE	-	-	1	1	1	1
J118	MN60A0837	メスタイ	KNIFE PAD (RIGHT)	-	-	1	1	1	1
J119	M90906010	サラネジ	SCREW 9/64 (40) X9.5	-	-	1	1	1	1
J120	MN60A0836	メスタイ	KNIFE PAD (LEFT)	-	-	-	-	1	-
J121	MN60A1742	フタ	COVER	-	-	-	-	1	-
J122	M91134015	ヒラネジ タンツキ	HINGED SCREW M5 (0.5) X10.5	-	-	1	1	2	1
J123	MP43A0910	リンク	LINK	-	-	-	-	1	-
J124	M91508022	ホルト	BOLT 15/64 (28) X12.5	-	-	-	-	1	-
J125	MN60A3228	ウデ	ARM	-	-	-	-	1	-
J126	M91111033	ピンネジ	PIN 11/64 (40) X6	-	-	1	1	2	1
J127	MN50A0910	リンク	LINK FOR REVERSE STITCHING	-	-	-	-	1	-
J128	M90550050	ミガキサガネ5	WASHER 5	-	-	-	-	2	-
J129	M91201022	ホルト	BOLT 3/16 (32) X9.5	-	-	-	-	2	-
J130	MN60A2228	ウデ	ARM	-	-	1	1	1	1
J131	M91509022	ホルト	BOLT 15/64 (28) X12.5	-	-	1	1	1	1
J132	M91271015	ヒラネジ タンツキ	SCREW M5 (0.5) X8.5	-	-	2	2	2	2
J133	MN72A0975	ロツトエント	BALL JOINT	-	-	1	1	1	1
J134	M91374045	ナツト ヒタリ M5	NUT M5	-	-	1	1	1	1
J135	M95004023	ウエコミホルト	STUD BOLT M5	-	-	1	1	1	1
J136	M91377045	ナツトM5	NUT M5	-	-	1	1	1	1
J137	MB61A0975	ロツトエント	CONNECTING LINK	-	-	1	1	1	1
J901	MN60A0950	レバークミタテ	LEVER ASSY	-	-	1	1	2	1

☑ 糸切り機構 (Ⅱ)
KNIFE MECHANISM (Ⅱ)

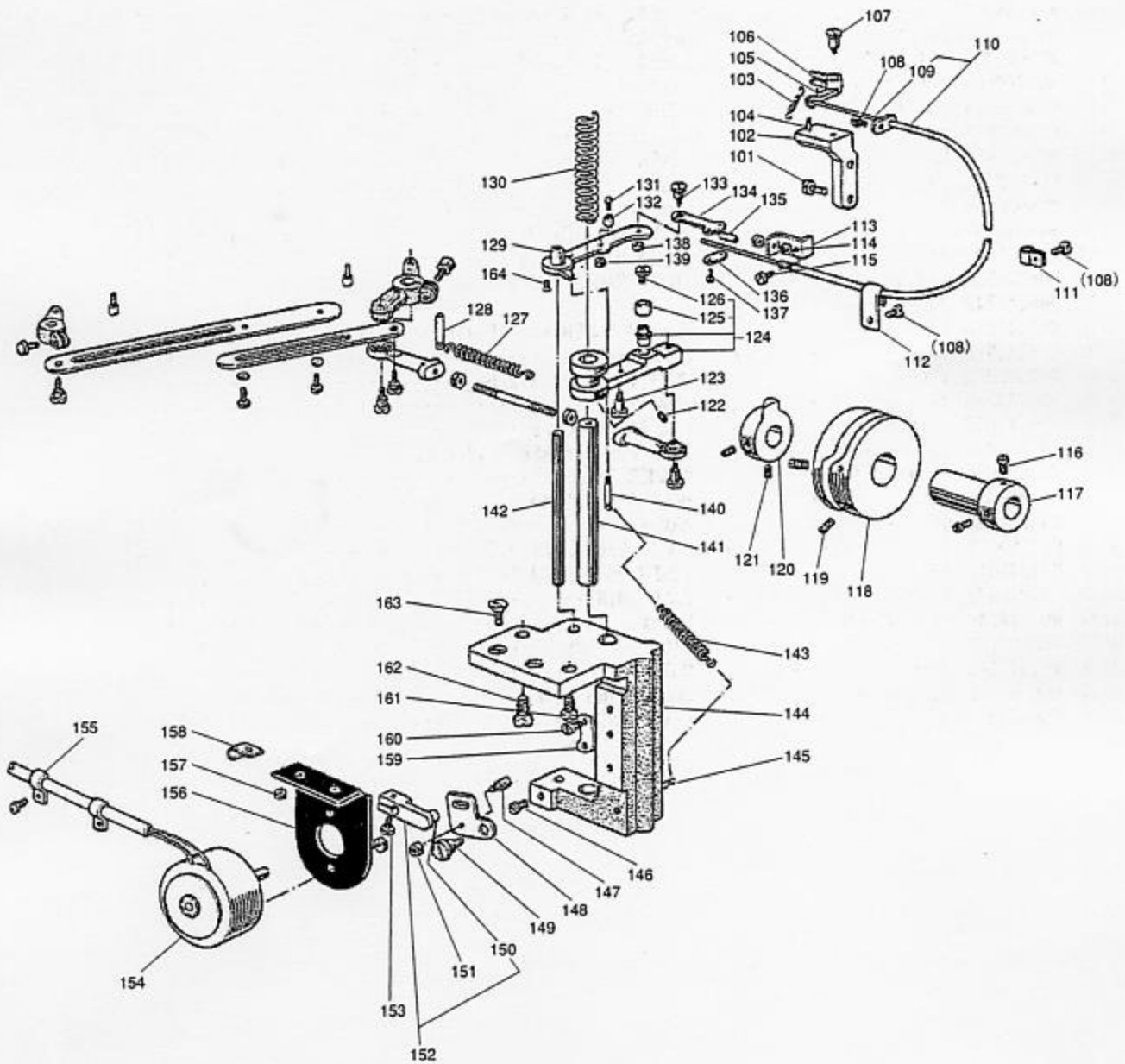

[K] 系切り機構 (II)
KNIFE MECHANISM (II)

Fig. No.	部品コード Parts No.	部品名	Description	使用個数 Amt. Req.					
				CS	CS	CS	CS	CS	CS
				4400	4420	4410	4410	4430	4412
K101	M91110002	ヒラネジ	SCREW 11/64 (40) X8	-	-	2	2	2	2
K102	MN60A0172	イトユルメダ イ	THREAD RELEASING BRACKET	-	-	1	1	1	1
K103	MN60A6572	ツルマキハネ	SPRING	-	-	1	1	1	1
K104	M91004067	ミゾ ツキヒン BXカ タ	PIN TYPE BX	-	-	1	1	1	1
K105	M91005067	ミゾ ツキヒン BXカ タ	PIN TYPE BX	-	-	1	1	1	1
K106	MN60A0173	イトユルメ	THREAD RELEASING PLATE	-	-	1	1	1	1
K107	M91112015	ヒラネジ タ ツキ	HINGED SCREW 11/64 (40) X15	-	-	1	1	1	1
K108	M91106004	ブ ラマイネジ	SCREW 11/64 (40) X8	-	-	4	4	4	4
K109	MN50A0746	フレキシブルワイヤ	FLEXIBLE WIRE	-	-	1	1	1	1
K110	MN60E0746	フレキシブルワイヤクミタテ	FLEXIBLE WIRE ASSY	-	-	1	1	1	1
K111	MN60A0620	ナイロンクリップ HP-5N	NYLON CLIP HP-5N	-	-	1	1	1	1
K112	M94003099	ナイロンクリップ HP-3N	NYLON CLIP HP-3N	-	-	1	1	1	1
K113	MN60A0601	トリツケイタ	MOUNTING PLATE	-	-	1	1	1	1
K114	M91373045	ナット M5	NUT M5	-	-	2	2	2	2
K115	M91109002	ヒラネジ	SCREW 11/64 (40) X7	-	-	1	1	1	1
K116	M91516002	ヒラネジ	SCREW 15/64 (28) X8.5	2	2	2	2	2	2
K117	MN50A0750	ブ ツシュ	BUSHING	-	-	1	1	1	1
K118	MN50A0350	イトキリカム	CAM FOR TRIMMER ACTUATOR	-	-	1	1	1	-
K118	MP69A0350	イトキリカム	THREAD TRIMMER CAM	-	-	-	-	-	1
K119	M91602020	ロツカクアナツキトメネジ	SCREW 1/4 (40) X10	-	-	2	2	2	2
K120	MN72A0350	カム	CAM	-	-	1	1	1	1
K121	M91055020	ロツカクアナツキトメネジ	SCREW M4X4	-	-	2	2	2	2
K122	M91001020	ロツカクアナツキトメネジ	SCREW 11/64 (40) X5	-	-	2	2	2	2
K123	M91111015	ヒラネジ タ ツキ	HINGED SCREW 11/64 (40) X9.2	-	-	1	1	1	1
K124	MN60A0886	ヨウトウウデクミタテ	CRANK FOR KNIFE DRIVING	-	-	1	1	1	1
K125	MN50A1411	コロ	ROLLER	-	-	1	1	1	1
K126	M90816002	ヒラネジ	SCREW 1/8 (44) X4.5	-	-	1	1	1	1
K127	MP60A3572	ツルマキハネ	SPRING	-	-	1	1	1	1
K128	M95003067	ミゾ ツキヒン BXカ タ	PIN TYPE BX	-	-	1	1	1	1
K129	MN60E0950	イトユルメレハクミタテ	THREAD RELEASING LEVER ASSY	-	-	1	1	1	1
K130	MN60A5572	ツルマキハネ	SPRING	-	-	1	1	1	1
K131	M91131015	ヒラネジ タ ツキ	HINGED SCREW 11/64 (40) X8	-	-	1	1	1	1
K132	MN50A0411	コロ	ROLLER	-	-	1	1	1	1
K133	M91231015	ヒラネジ タ ツキ	HINGED SCREW 3/16 (28) X9	-	-	1	1	1	1
K134	MN72A1601	トリツケイタ	MOUNTING PLATE	-	-	1	1	1	1
K135	MN72A1750	ブ ツシュ	BUSHING	-	-	1	1	1	1
K136	MF36A0750	ブ ツシュ	BUSHING	-	-	1	1	1	1
K137	M90825002	ヒラネジ	SCREW 1/8 (44) X7	-	-	2	2	2	2
K138	M91201045	ナット	NUT 3/16 (28)	1	1	1	1	1	1
K139	M91107045	ナット	NUT 11/64 (40)	-	-	1	1	1	1
K140	M91111030	トクシユネジ	SPECIAL SCREW 11/64 (40) X4	-	-	1	1	1	1
K141	MN50A3454	ジク	SHAFT	-	-	1	1	1	1
K142	MN60A0454	ジク	SHAFT	-	-	1	1	1	1
K143	MN50A3572	ツルマキハネ	COIL SPRING	-	-	1	1	1	1
K144	MP66A0603	トリツケイタ	MOUNTING BASE	-	-	1	1	1	1
K145	M90560060	ミゾ ツキヒン BX カ タ	PIN TYPE BX 5X24	-	-	1	1	1	1
K146	M91102002	ヒラネジ	SCREW 11/64 (40) X8.5	-	-	1	1	1	1
K147	M91111033	ヒラネジ	SCREW 11/64 (40) X6	-	-	1	1	1	1
K148	MN50A3950	レハ	LEVER	-	-	1	1	1	1
K149	M91103016	マルヒラネジ タ ツキ	HINGED SCREW 11/64 (40) X6.8	-	-	1	1	1	1
K150	M90615063	タ ツキヒン	HINGED PIN	-	-	1	1	1	1
K151	M91101045	ナット	NUT 11/64 (40)	-	-	1	1	1	1
K152	MP61E0228	ウデクミタテ	ARM ASSY FOR ROTARY SOLENOID	-	-	1	1	1	1
K153	M91112002	ヒラネジ	SCREW 11/64 (40) X12	-	-	1	1	1	1
K154	MP61E0519	ソレノイドクミタテ	SOLENOID ASSY	-	-	1	1	1	1
K155	MF10A0689	ホルダ	HOLDER	-	-	2	2	2	2
K156	MN50A3601	トリツケイタ	SETTING PLATE	-	-	1	1	1	1
K157	M91373045	ナット M5	NUT M5	-	-	2	2	2	2
K158	MN50A0780	ホルダ	HOLDER	-	-	1	1	1	1
* K159	MN50A0477	ストッパ	STOPPER	-	-	1	1	1	1
K160	M91109002	ヒラネジ	SCREW 11/64 (40) X7	-	-	2	2	2	2
K161	M91602003	マルヒラネジ	SCREW 1/4 (24) X13	-	-	1	1	1	1
K162	M91603003	マルヒラネジ	SCREW 1/4 (24) X16	-	-	1	1	1	1
K163	M95001037	Pサラネジ 5X16	SCREW M5X16	-	-	2	2	2	2
K164	M90803010	サラネジ	SCREW 1/8 (44) X6	-	-	3	3	3	3

□ タッチバック・検出器機構
TOUCH BACK & DETECTOR MECHANISM

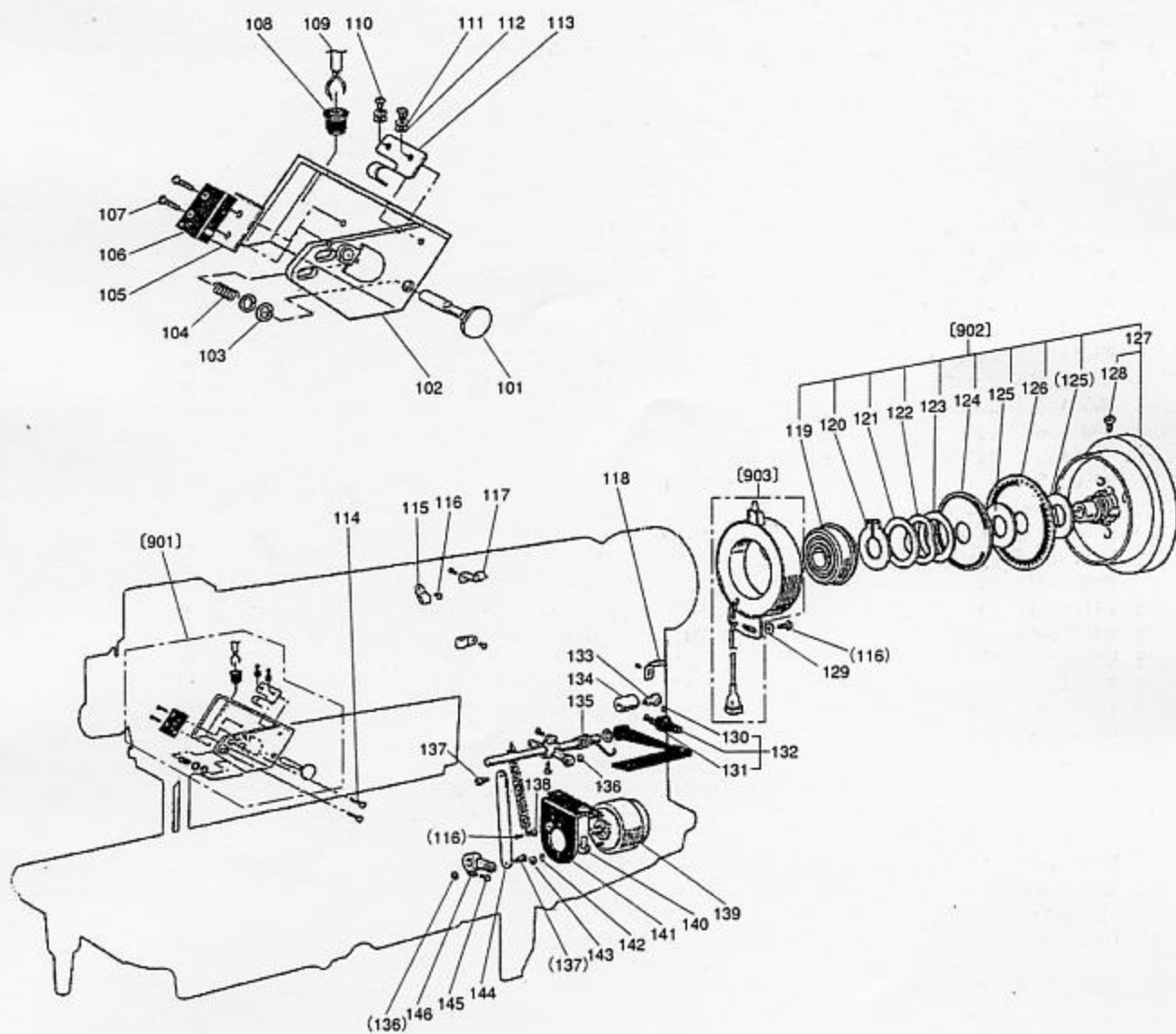

[L] タッチバック・検出器機構
TOUCH BACK & DETECTOR MECHANISM

Fig. No.	部品コード Parts.No.	部品名	Description	使用個数 Amt. Req. 各					
				4400	4420	4410	4410-03	4430	4412-03
L101	MP60E0270	ボタ ン	PUSH BUTTON	-	-	1	1	1	1
L102	MP60A2601	スイッチトリツケイタ	SWITCH MOUNTING PLATE	-	-	1	1	1	1
L103	M90512065	エカ トラメワ 3	RETAINING RING (E TYPE)	-	-	2	2	2	2
L104	MF00A7572	ツルマキハ ネ	SPRING	-	-	1	1	1	1
L105	MF01A0502	ゼ ツエンイタ	INSULATOR SEET	-	-	1	1	1	1
L106	M90208099	マイクロスイッチ	MICRO SWITCH SS-5	-	-	1	1	1	1
L107	M90251037	Pハ イント ネジ	SCREW M2X8	-	-	2	2	2	2
L108	M91004080	ゴム ツシユ	RUBBER PLUG	-	-	1	1	1	1
L109	M97348099	コード クミタテ	CODE ASSY	-	-	1	1	1	1
L110	M90252037	Pナハ ネジ	SCREW M2X3	-	-	2	2	2	2
L111	M90306053	ハ ネザ ガ ネ	SPRING WASHER 2	-	-	2	2	2	2
L112	M90315050	コザ ガ ネ M2	WASHER 2	-	-	2	2	2	2
L113	MF00A0192	イタハ ネ	SPRING PLATE	-	-	1	1	1	1
L114	M95043021	ロツカクアナツキホ タンホ ルト	SCREW M5X6	-	-	2	2	2	2
L115	M94003099	ナイロンクリップ HP-3N	NYLON CLIP HP-3N	-	-	2	2	2	2
L116	M91106004	プ ラマイネジ	SCREW 11/64 (40) X8	-	-	2	2	2	2
L117	MN50A1780	ホルダ	HOLDER	-	-	1	1	1	1
L118	MQ60A1780	ホルダ	HOLDER	-	-	1	1	1	1
L119	MN10A1456	ジ ヲウケ	BUSHING	-	-	1	1	1	1
L120	M90330065	カ トラメワ	RETAINING RING-C TYPE 30	-	-	1	1	1	1
L121	M93001050	ザ ガ ネ	WASHER	-	-	1	1	1	1
L122	MF01A0259	ハンシヤハ ンオサエスフ リンク	SUPPORTER SPRING	-	-	1	1	1	1
L123	MF01A1476	スハ ーサB	SPACER B	-	-	1	1	1	1
L124	MN72A1694	ハンシヤハ ンF20	SPEED COMMAND DISC F20 (UP)	-	-	1	1	1	1
L125	MF01A0476	スハ ーサA	SPACER A	-	-	2	2	2	2
L126	MN82A0694	ハンシヤハ ンF11	SPEED COMMAND DISC (F11)	-	-	1	1	1	1
L127	MP61E1682	プ ーリクミタテ	PULLEY ASSY	-	-	1	1	1	1
L128	M91520002	ヒラネジ	SCREW 15/64 (28) X12	-	-	2	2	2	2
L129	M93002050	ザ ガ ネ	WASHER	-	-	1	1	1	1
L130	M91506001	トメネジ	SET SCREW 15/64 (28) X6	-	-	1	1	1	1
L131	M91519002	ヒラネジ	SCREW 15/64 (28) X7.5	-	-	1	1	1	1
L132	MN72A1950	レバ ークミタテ	LEVER ASSY	-	-	1	1	1	1
L133	M91516015	ヒラネジ タ ンツキ	HINGED SCREW 15/64 (28) X17	-	-	1	1	1	1
L134	MN50A0417	ゴム	RUBBER RING	-	-	1	1	1	1
L135	MP61A0729	ヒネリハ ネ	SPRING	-	-	1	1	1	1
L136	M91502045	ナツト	NUT 15/64 (28)	-	-	2	2	2	2
L137	M91517015	ヒラネジ タ ンツキ	HINGED SCREW 15/64 (28) X17.2	-	-	2	2	2	2
L138	M91101045	ナツト	NUT 11/64 (40)	-	-	1	1	1	1
L139	MN72E1519	ソレノイド クミタテ	SOLENOID	-	-	1	1	1	1
L140	M98004022	ボ ルト	BOLT M8X12	-	-	2	2	2	2
L141	MP47A2601	トリツケイタ	MOUNTING PLATE	-	-	1	1	1	1
L142	M90104053	ハ ネザ ガ ネ	SPRING WASHER 6	-	-	2	2	2	2
L143	M91574045	ナツト	NUT M6	-	-	2	2	2	2
L144	MN50A2910	リンク	LINK	-	-	1	1	1	1
L145	M91502022	ボ ルト	BOLT 15/64 (28) X16	-	-	1	1	1	1
L146	MN50A5228	ウデ	ARM FOR TOUCH BACK SOLENOID	-	-	1	1	1	1
L901	MP61E1534	タッチスイッチクミタテ	SWITCH ASSY	-	-	1	1	1	1
L902	MP61E0682	プ ーリクミタテ	PULLEY ASSY	-	-	1	1	1	1
L903	MB60A2406	ケンシユツクミタテ	DETECTOR BRACKET ASSY	-	-	1	1	1	1

給油機構

OIL LUBRICATION MECHANISM

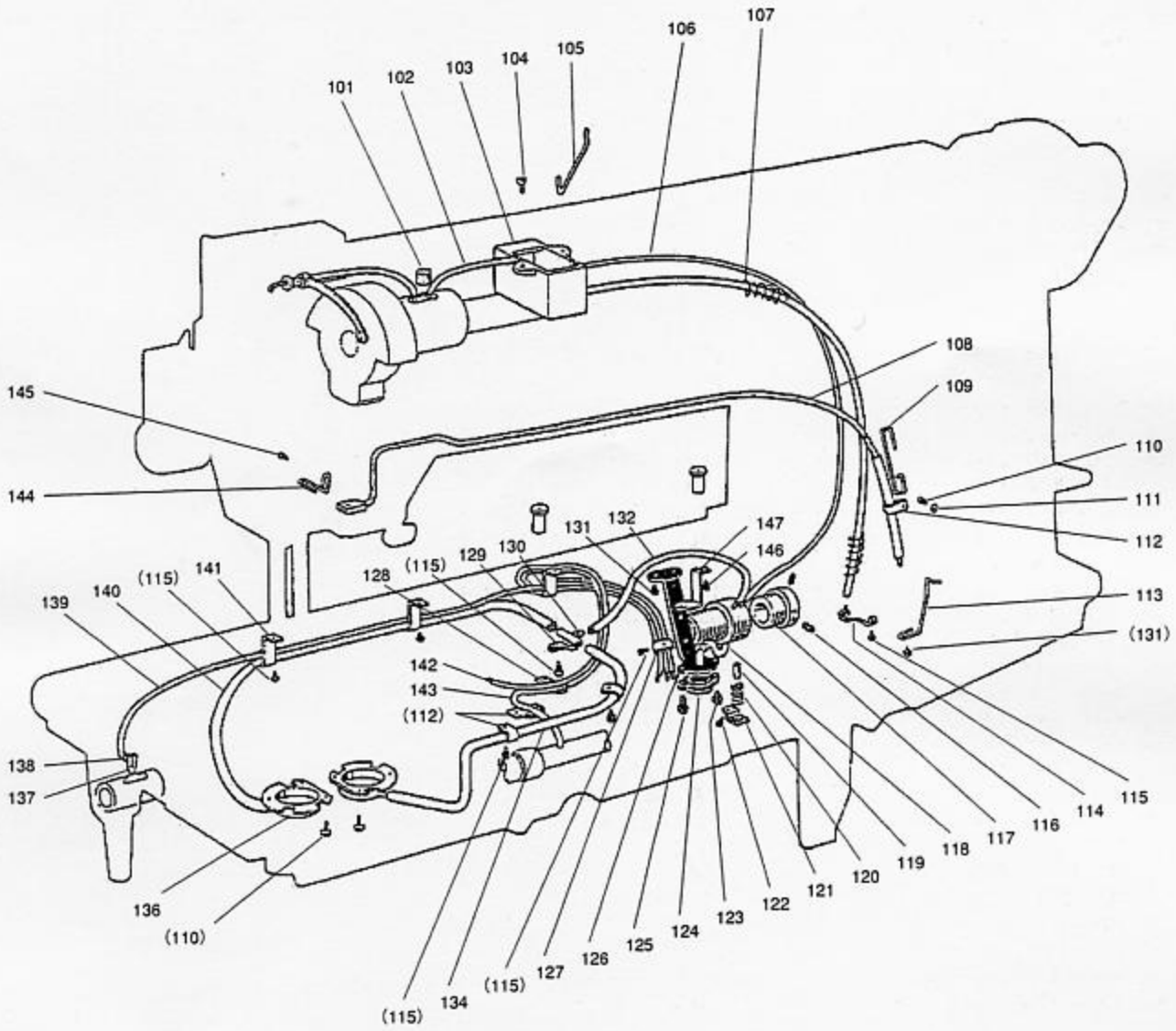

[M] 給油機構
OIL LUBRICATION MECHANISM

Fig. No.	部品コード Parts. No.	部品名 Description	使用個数 Amt. Req. 台					
			4400	4420	4410	4410-ES	4430	4412-ES
M101	MP40A3740	フェルト	1	1	1	1	1	1
M102	MP40E2688	パイプヒモクミタテ	1	1	1	1	1	1
M103	MN40E0138	オイルタンククミタテ	1	1	1	1	1	1
M104	M91402010	ボルトウサネジ	2	2	2	2	2	2
* M105	MN70A0780	ホルダ	1	1	1	1	1	1
M106	MP40A0688	パイプ	1	1	1	1	1	1
M107	MP60E0688	パイプパイプクミタテ	1	1	1	1	1	1
M108	MP40E1688	パイプフェルトクミタテ	1	1	1	1	1	1
M109	MF36A0680	ハリガネ	1	1	1	1	1	1
M110	M90903002	ヒラネジ	4	7	4	4	7	4
M111	M90304053	パイプネジガネ 3.5	1	1	1	1	1	1
M112	MF10A0689	ホルダ	4	4	4	4	4	4
M113	MP60A1689	ホルダ	1	1	1	1	1	1
M114	MP60A2689	ホルダ	1	1	1	1	1	1
M115	M91107002	ヒラネジ	8	9	8	8	9	8
M116	M91111001	トメネジ	2	2	2	2	2	2
M117	MP47A3750	ブッシュ	1	1	1	1	1	1
M118	MP40A2688	パイプ	1	1	1	1	1	1
M119	M95007063	トクシピン	1	1	1	1	1	1
M120	MN40A1572	コイルバネ	1	1	1	1	1	1
M121	MN40A0705	パイプサエ	1	1	1	1	1	1
M122	M90805002	ヒラネジ	1	1	1	1	1	1
M123	M90944003	マルヒラネジ	1	1	1	1	1	1
M124	MP60A0337	フィルタークミタテ	1	1	1	1	1	1
M125	M90905003	マルヒラネジ	1	1	1	1	1	1
M126	MP60E0601	トリツケイタクミタテ	1	1	1	1	1	1
M127	MP40A4689	ホルダ	1	1	1	1	1	1
M128	MQ60A2780	ホルダ	1	1	1	1	1	1
M129	MN70A8780	ホルダ	-	1	-	-	1	-
M130	MP40A0571	パイプジョイント	-	1	-	-	1	-
M131	M91109004	パイプネジガネ ラマイネジ	3	3	3	3	3	3
M132	MP60A0688	パイプ	1	-	1	1	-	1
M133	MP48A0688	パイプ	-	1	-	-	1	-
M134	MP40A3688	パイプ	-	1	-	-	1	-
M136	MN50A3742	フタクミタテ	1	2	1	1	2	1
M137	MF10E2148	ヒモ	2	3	2	2	3	2
M138	MF10E2148	ヒモ	1	1	1	1	1	1
M139	MP40A5688	パイプ	1	1	1	1	1	1
M140	MP40A4688	パイプ	-	1	-	-	1	-
M141	MN70A5780	ホルダ	3	3	2	2	2	2
M142	MP40E3688	パイプヒモクミタテ	1	1	1	1	1	1
M143	MP40E4688	パイプヒモクミタテ	1	1	1	1	1	1
M144	MP60A0689	ホルダ	1	1	1	1	1	1
M145	M91138002	ヒラネジ	1	1	1	1	1	1
M146	M91118004	パイプネジガネ ラマイネジ	1	1	1	1	1	1
M147	MQ60A0429	パイプサエ	1	1	1	1	1	1



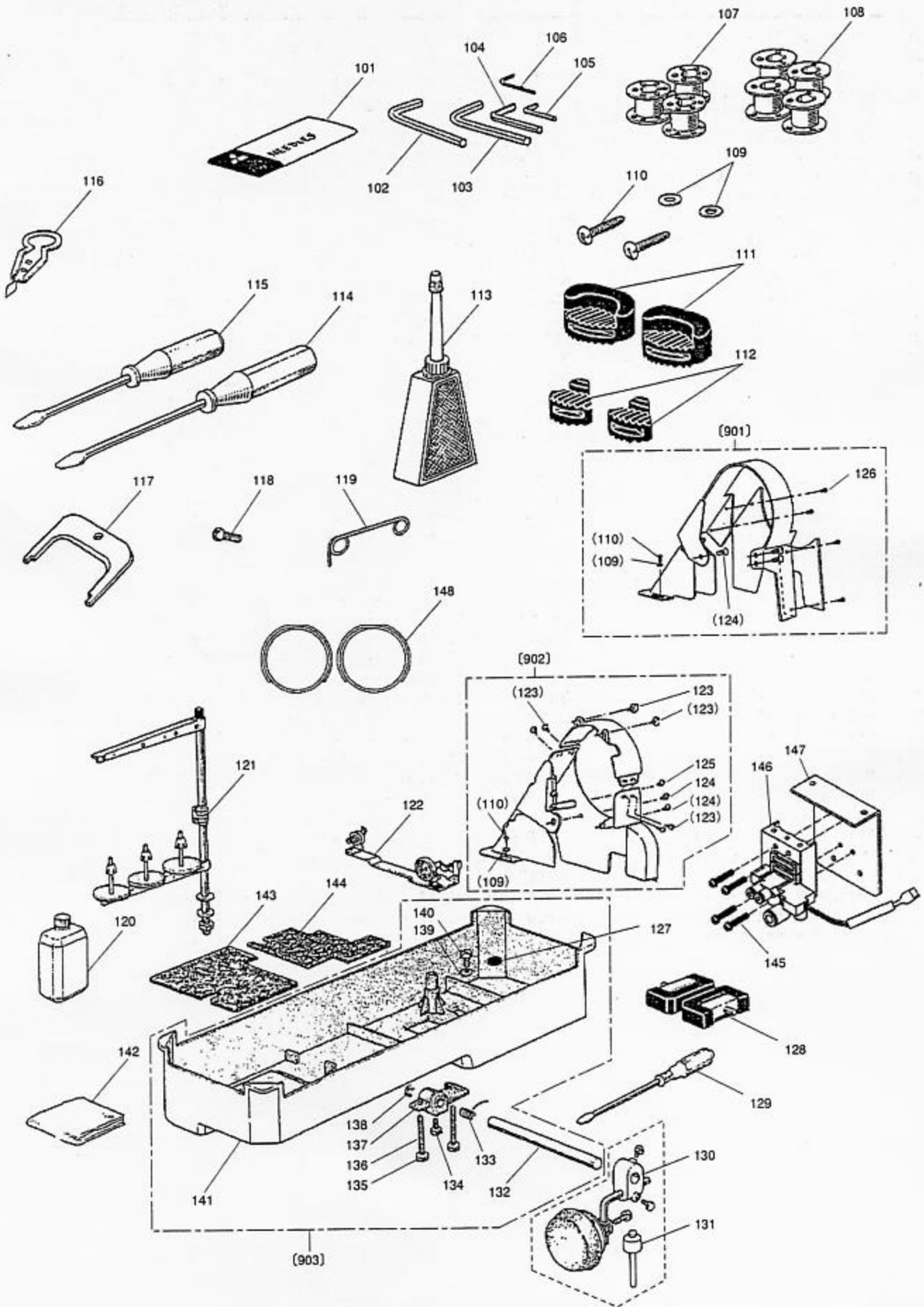















N 付属品
 ACCESSORIES



[N] 付属品
ACCESSORIES

Fig. No.	部品コード Parts.No.	部品名	Description	使用個数 Amt. Req.					
				4400	4420	4410	4410-C	4430	4412-C5
N101	MP20B0128	ミシハリ DPX17-23	NEEDLE DPX17-23	3	6	3	3	6	3
N102	MS01A1976	スパナ ロツカクホウ 4	SOCKET WRENCH 4	1	1	1	1	1	1
N103	MS01A0976	スパナ ロツカクホウ 3	SOCKET WRENCH 3	-	-	1	1	1	1
N104	MS02A1976	スパナ ロツカクホウ 2.5	SOCKET WRENCH 2.5	1	1	1	1	1	1
N105	MS02A0976	スパナ ロツカクホウ 2	SOCKET WRENCH 2	-	-	1	1	1	1
N106	MS10A0976	スパナ ロツカクホウ 1.5	SOCKET WRENCH 1.5	-	1	-	-	1	-
N107	MN12B0123	ボビン	BOBBIN	3	4	-	-	-	-
N108	MP60A0123	ボビン	BOBBIN	-	-	3	3	4	3
N109	M90511050	ミカキザガネ	WASHER 5	4	4	4	4	4	4
N110	M90409041	マルモクネジ	WOOD SCREW 4.5X20	4	4	4	4	4	6
N111	MN70A0419	ボウシンゴム	VIBRATION PERVENTING RUBBER	2	2	2	2	2	2
N112	MN70A1419	ボウシンゴム	VIBRATION PERVENTING RUBBER	2	2	2	2	2	2
N113	MF60A0137	アブラサシ	OILER	1	1	1	1	1	1
N114	MB02A0608	ネジ マウシ(チュウ)	SCREW DRIVER (MIDDLE)	1	1	1	1	1	1
N115	MB02A1608	ネジ マウシ(ショウ)	SCREW DRIVER (SMALL)	1	1	1	1	1	1
N116	MN10A0172	イトオシキクミタテ	THREAD A NEEDLE KIT	1	1	1	1	1	1
N117	MF01A0565	カクドチヨウセイゲ	SPEED COMMAND DISC ADJUSTING PLATE	-	-	1	1	1	1
N118	M90305037	Pナネネジ	SCREW M3X6	-	-	1	1	1	1
N119	MN82A0180	イトアンナイ	THREAD GUIDE	-	-	1	1	1	1
N120	MN70E0149	アブラカン	OIL CAN	1	1	1	1	1	1
N121	MF47E0193	イトタテガイ	COTTON STAND	1	-	1	1	-	1
N121	MP48E0193	イトタテガイクミタテ 3	COTTON STAND	-	1	-	-	1	-
N122	MG52A0190	イトマキシカケ	BOBBIN WINDER ASSY.	1	1	-	-	-	-
N122	MF03E1193	イトマキシカケ	BOBBIN WINDER ASSY.	-	-	1	1	1	1
N123	M91118004	ザカネツキフ ラマイネジ	SCREW 11/64(40)X7	-	-	6	6	6	6
N124	M91508004	フ ラマイネジ	SCREW 15/64(28)X8	3	3	2	2	2	2
N125	M91072004	SW-PWツキ Pナネネジ	SCREW M4X14	-	-	1	1	1	1
N126	M91114004	フ ラマイネジ	SCREW 11/64(40)X5.5	4	4	-	-	-	-
N127	M90701099	OP-S ジシヤク	MAGNET BLOCK	1	1	1	1	1	1
N128	MF01E0418	チヨウバヒンセット	HINGE WITH RUBBER CUSHION	2	2	2	2	2	2
N129	MF00A0608	ネジ マウシ(ダイ)	SCREW DRIVER (LARGE)	1	1	1	1	1	1
N130	MN40E0727	コモノヒンセット	KNEE LIFTER ASSY.	1	1	1	1	1	1
N131	MN40A0578	ヒザアゲヒンクミタテ	KNEE LIFTER LIFTING ROD	1	1	1	1	1	1
N132	MF20A1723	ヒザアゲシク	KNEE LIFTER BAR	1	1	1	1	1	1
N133	MF20A1729	ヒネリハネ	TWIST SPRING	1	1	1	1	1	1
N134	M92005031	トクシユホルト	BOLT	1	1	1	1	1	1
N135	M91501045	ナット	NUT 15/64(28)	2	2	2	2	2	2
N136	M91520001	トメネジ	SET SCREW 15/64(28)X27	2	2	2	2	2	2
N137	MN70A0724	ヒザアゲウデ	KNEE LIFTER CRANK	2	2	2	2	2	2
N138	M90515065	エカタメワ 9	RETAINING RING E TYPE 9	1	1	1	1	1	1
N139	M97001052	トクシユザガネ	WASHER 8	1	1	1	1	1	1
N140	M92002002	ヒラネジ	SCREW 5/16(28)X10	1	1	1	1	1	1
N141	MN40A0139	アブラソウ	OIL RESERVOIR	1	1	1	1	1	1
N142	MF60A0734	ビニールカバー	VINYL COVER	1	1	1	1	1	1
N143	MN70A3740	フェルト	FELT	1	1	1	1	1	1
N144	MN70A4740	フェルト	FELT	1	1	1	1	1	1
N145	M91066004	SW-PW フ ラマイナネジ	SCREW	-	-	-	-	-	4
N146	MP69E0599	ソレノイドバルブ	SOLENOID VALVE ASSEMBLY	-	-	-	-	-	1
N147	MB61A5601	レキユレータリツケイタ	SOLENOID VALVE MOUNTING PLATE	-	-	-	-	-	1
N148	MP47A0567	エアチューブ	URETHANE TUBE	-	-	-	-	-	2
N901	MP60E0776	ベルトカバーセット	BELT COVER ASSY	1	1	-	-	-	-
N901	MP60E1776	ベルトカバーセット(国内用)	BELT COVER ASSY (FOR CE)	1	1	-	-	-	-
N902	MP61E3776	ベルトカバーセット	BELT COVER ASSY	-	-	1	1	1	1
N902	MP61E4776	ベルトカバーセット(国内用)	BELT COVER ASSY (FOR CE)	-	-	1	1	1	1
N903	MN70E0139	アブラソウセット	OIL RESERVOIR ASSY	-	1	1	1	1	1

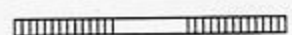
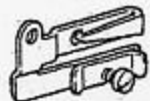
㊦ ゲージ部品表
GAUGE PARTS LIST

針板 Needle Plate	内押え Presser Foot (Inside)	外押え Presser Foot (Outside)	針ダキ Needle Clamp	送り Feed Dog	スベリ板(左) Slide Plate (L)	スベリ板(右) Slide Plate (R)
 1/8~5/16	 1/8~5/16	 1/8~5/16	 1/8~5/16	 1/8~5/16		
 3/8~5/8	 3/8~5/8	 3/8~5/8	 3/8~5/8	 3/8~5/8		
 3/4~1	 3/4~1	 3/4~1	 3/4~1	 3/4~1	Fig.J135 植込ミボルト Connecting bolt	
						
					1/8~5/8 M95004023	3/4~1 M95006023
					Fig. A901 糸案内(組) A902 Thread guide (complete)	
						
1/8~3/8 MP62E0180		1/2~1 MN62E0180				

□ ゲージ部品表
GAUGE PARTS LIST

針幅寸法 Gauge Size	針板 Needle Plate	内押え Presser Foot (Inside)	外押え Presser Foot (Outside)	針ダキ Needle Clamp	送り Feed Dog	スベリ板(左) Slide Plate (L)	スベリ板(右) Slide Plate (R)
LU2-4400-B0B							
	MP40B0101	MP00B0107	MP61E0105		MP40B0104	MP00B0473	MP60A0474
LU2-4410-B1T							
	MP61A2101	MP00B0107	MP61E0105		MP41B0104	MP00B0473	MP61A0474
LU2-4410-B1T-CS							
	MP61A2101	MP00B0107	MP61E0105		MP61A0104	MP00B0473	MP61A0474
LU2-4412-B1T-CS							
	MP69A0101	MP00B0107	MP61E0105		MP69A0104	MP00B0473	MP61A0474
LU2-4420-B0B							
1/8 (3.2mm)	MP42J4101	MP20J4107	MP20J4106	MP20J4102	MP20J4104	MN10A0473	MN10A0474
5/32 (4mm)	MP42J5101	MP20J5107	MP20J5106	MP20J5102	MP20J5104	MN10A0473	MN10A0474
3/16 (4.8mm)	MP42J6101	MP20J6107	MP43J6106	MP43J6102	MP43J6104	MN10A0473	MN10A0474
1/4 (6.4mm)	MP42J8101	MP20J8107	MP62A0106	MP20J8102	MP20J8104	MN10A0473	MN10A0474
5/16 (8mm)	MP42J9101	MP20J9107	MP20J9106	MP20J9102	MP20J9104	MP20B1473	MN10A0474
3/8 (9.5mm)	MP42K1101	MP20K1107	MP20K1106	MP20K1102	MP20K1104	MP20B1473	MN10A0474
1/2 (12.7mm)	MP42K3101	MP20K3107	MP20K3106	MP20K3102	MP20K3104	MP00B0473	MN10A0474
5/8 (16mm)	MP42K4101	MP20K4107	MP20K4106	MP20K4102	MP20K4104	MP00B0473	MN10A0474
3/4 (19mm)	MP42K5101	MP20K5107	MP20K5106	MP20K5102	MP20K5104	MP20B2473	MP20B2474
1 (25.4mm)	MP42K6101	MP20K6107	MP20K6106	MP20K6102	MP20K6104	MP20B3473	MP20B2474
LU2-4430-B1T							
1/8 (3.2mm)	MP43J4101	MP20J4107	MP20J4106	MP20J4102	MP43J4104	MN50A0473	MN72A1474
5/32 (4mm)	MP43J5101	MP20J5107	MP20J5106	MP20J5102	MP43J5104	MN50A0473	MN72A1474
3/16 (4.8mm)	MP43J6101	MP20J6107	MP20J6106	MP43J6102	MP43J6104	MN50A0473	MN72A1474
1/4 (6.4mm)	MP43J8101	MP20J8107	MP62A0106	MP20J8102	MP43J8104	MN50A0473	MN72A1474
5/16 (8mm)	MP43J9101	MP20J9107	MP20J9106	MP20J9102	MP43J9104	MN50A1473	MN72A1474
3/8 (9.5mm)	MP43K1101	MP20K1107	MP20K1106	MP20K1102	MP43K1104	MN50A1473	MN72A1474
1/2 (12.7mm)	MP43K3101	MP20K3107	MP20K3106	MP20K3102	MP43K3104	MN50A2473	MN72A1474
5/8 (16mm)	MP43K4101	MP20K4107	MP20K4106	MP20K4102	MP43K4104	MN50A2473	MN72A1474
3/4 (19mm)	MP43K5101	MP20K5107	MP20K5106	MP20K5102	MP43K5104	MN50A3473	MN72A2474
1 (25.4mm)	MP43K6101	MP20K6107	MP20K6106	MP20K6102	MP43K6104	MN50A4473	MN72A2474

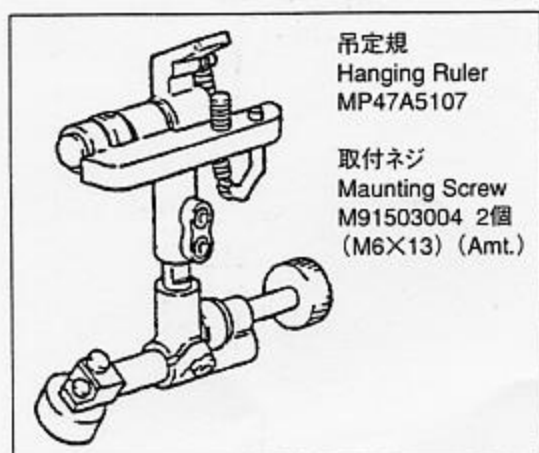





吊定規
Hanging Ruler
MP47A5107

取付ネジ
Mounting Screw
M91503004 2個
(M6×13) (Amt.)

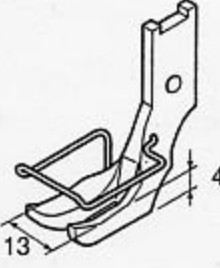
Q オプションパーツ
OPTION PARTS

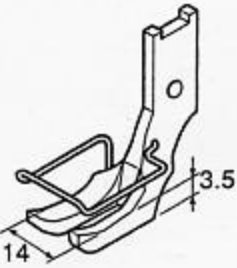
LU2-4400-B0B、LU2-4410-B1T (-CS)、LU2-4412-B1T-CSオプションパーツ OPTION PARTS

内押え Presser Foot (inside)	外押え Presser Foot (outside)	内押え Presser Foot (inside)	外押え Presser Foot (outside)
 <p>MP00B0107</p>	 <p>MP61E0105</p>	 <p>MP66A2107</p>	 <p>MP66AE0106</p>
 <p>MP66A0107</p>		 <p>MP66A4107</p>	

LU2-4410-B1T (-CS) オプションパーツ OPTION PARTS

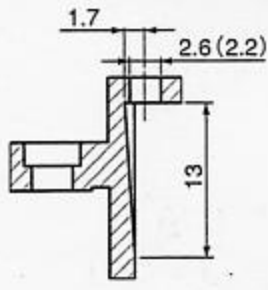
部品名	Description	部品コード Parts. No.	針穴寸法 Needle hole	針受け寸法 Dimension
送り	Feed Dog	MP61A0104	3.8×2.6	
送り	Feed Dog	MP41B0104	4.5×2.6	
送り	Feed Dog	MP41B1104	3.2×2.2	
送り (細針対応)	Feed Dog	MP61A1104	3.8×2.6	